

# Husqvarna Report

3rd Newsletter for Husqvarna Motorcycle Club

## Gunnar Lindstrom Wins with Husqvarna Motorcycles

The Husqvarna Motorcycle Club received a great postcard from a past champion Husqvarna rider and we wanted to share it with you all.

Gunnar Lindstrom was the hero of most Husky riders of the late 60's and thru out the 70's. The newsletter editor will make an effort to interview Gunnar for a future issue.

Check out the period riding gear:

Full Bore boots

Jofa mouth guard

Carrara goggles

Chest protector

Yellow jersey?

Black pants/yellow stripe?

Bell helmet?

I certainly remember striving to look this cool. I didn't even know what a Jofa mouth guard was for, but I had to have one!

Look at the rims already full of mud, but not much on the rider or front number plate.

I would bet he is out front of the pack.

Notched number plate to let the throttle cable have a cleaner route.

Guards over the Magura levers.

Wide Husky handlebars with the high cross bar.

Front brake is to the left, but what I find unusual is the pull is to the front. Why is this? Maybe the cable attachment is at the fork boot? Looks like a 250 4 Speed around 1971. Gas tank shape is

also unusual. We are honored to have Gunnar as a new member!



### CONTENTS

Husky RED Paint Formula.

**Husky Letters**

*Classifieds*

*Model Number Reference*

*1979 250 Tuning Specs*

*Silverpilen*

## Husqvarna RED Paint Formula

In our first newsletter we were able to share the formula that many find correct for the silver used on most Husqvarna models 1957 thru 1982. This next formula is for the solid red color used on many Husqvarna for 1968 thru 1974 and probably up to '82. The color is a computer match of several NOS Husky pieces that have never seen daylight. Interestingly they all were in sync for a great match!

Dupont Chromabase B/C

Car: BMW

Code:274 Yr:1993

Color: Mugello Red

Mix size: Pint Cost: \$32.20

Tinting Guide:

850J Brilliant Red	75.3
852J Orange	106.8
853J Red Orange	120.1
801J HS White	125.9
806J HS Black	128.6
150K B/C Balancer	355.0
175K Binder	446.3

This is a Dupont Chromabase formula

There is also a request for OEM engine black paint and I could use some member help and experience on this. I have been using PlastiCote spray can paint for non durable application on show bikes and I believe the number is # 230 Flat Black. Usually available at Pep Boys or Walmart or? It looks okay to me, but it is not real durable.

There is also PlastiCote #215 semi gloss Black, but I did not think it matched as well. I am sure this could be a disputable preference.

Any good experience with other engine black please let me know. Thanks

### Plating Hardware-

If you are doing restoration and you want a good plating job on your Bufo hardware, check out the ad for Chemical Plating Corp.

This process is simple with only heat, no batteries.

**WANTED to BUY - Husqvarna literature all years - Call Craig at 304-267-6471 or e-mail husky@intrepid.net**

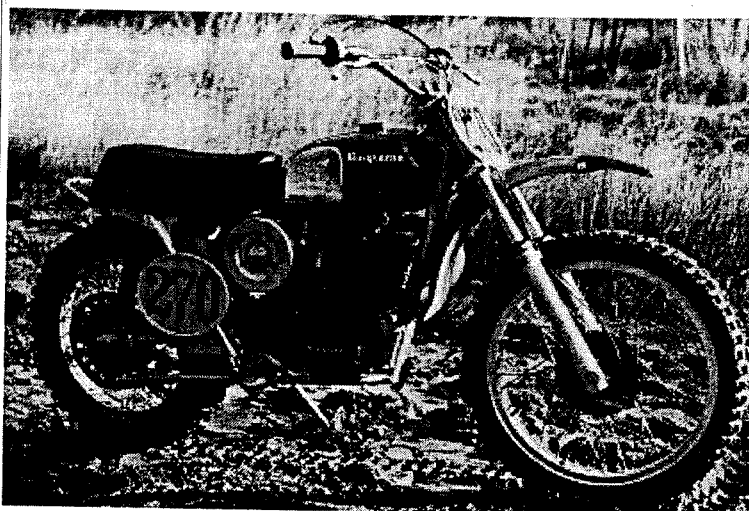

Henry Schnackenberg's 72 450WR AHRMA racer

## Husky Letters

I have a '82 250XC...and just replaced the fork seals...using KYB (Kayaba) seals. They are available from Kawasaki: 92049-1045 or 92049-1251 and Yamaha: 26H-23145-00. They are 40 mm x 52 mm seals and should fit most 40 mm Husky forks from '82 onward.

Steve Ames

*Thanks for the tip, Steve. This not only applies to forks, but many of the seals within the engine can be replaced with seals of Japanese origin, normally at a reduced price with greater longevity. Just try to match the inner and outer diameter, plus the height. As an example, all the Husky 35 mm forks, including Betor, can use a Honda seal. In the next issue I'll try to find the correct part #.*

My '76 360 Automatic...ran for 25 minutes...and a retaining clip broke on a transmission shaft...and all the one-way (sprag) bearings have grenaded. I would be interested in a whole 360A engine...or will trade for other parts.

Brian DeVore

*FYI: It is normal practice to consider transmission clips (manual or auto) as "one time use only." These clips are formed by a stamping process which results in one rounded and one sharp edge. The sharp edge must ALWAYS face away from the spinning gear to*

*avoid it being inadvertently unseated with catastrophic results. Even installed correctly, after many miles the thickness of the clip gets worn away by the spinning gear which results in more gear sideplay and can lead to nothing but bad things. Does anyone out there have parts for a 360A?*

I just picked up a '71 400 Motocross...I don't really know much about these bikes.

Dave Jones

*During 1969-70, Bengt Aberg rode a "400 Cross" to the open class world motocross championship with his closest rival being Arne Kring on a similar mount. With the exception of cylinder porting, these bikes were very close to showroom models: no trick parts. Your '71 Cross is the final version of the bikes ridden by Aberg/Kring and were considered the ultimate privateer's weapon for open class motocross. It's also the last of the 4-speed engines, dating back to the mid-1960s.*

### Husky Trivia

During the night portion of the 1969 Baja 1000, Husky's Gunnar Nilsson ate it big time. When he awoke he didn't know where he was but it was pitch black and no one ever told him Valhalla would be so warm with sand and cactus. He finally remembered - ya, ya - he was in Mexico for some crazy race. Malcolm Smith had given Gunnar a big lead plus he'd been able to extend it further in spite of never having been to the desert. He was so far in front that not a sound was heard nor could a light be seen. It took him 20-minutes to find his bike and another few to find the race course. Not knowing which direction was right, he just took off and by good fortune was still the first vehicle to the finish in La Paz.

*Editors Note : Thank you member Tosh Konya for Husky Letters technical answers and Triva.*

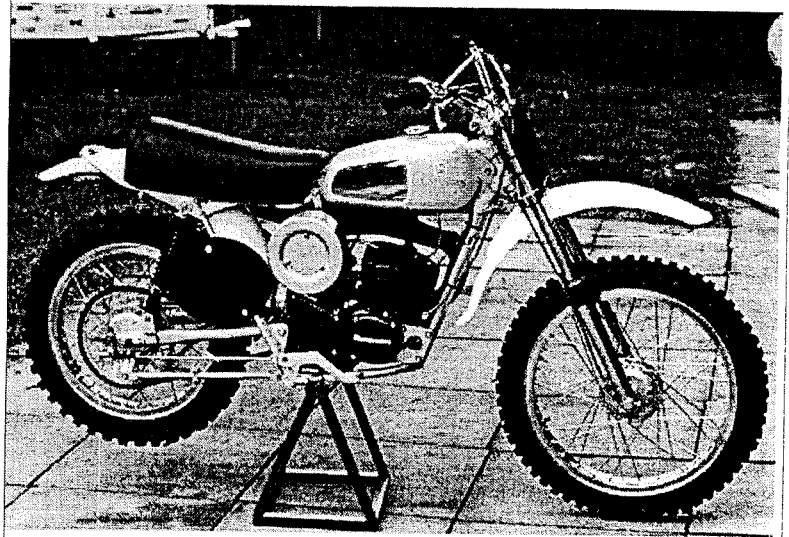

**Brian Watson's beautiful 73 125 Australian racer**

## Classifieds

**1979 Husqvarna 390CR-** \$925 very good condition. Has new fork seals and air filter. Was stored since 1980. Runs like gangbusters. Call Paul 216-988-7160 in Ohio.

**Wanted for Automatic-** original owners manual for 1976 360 Automatic, no copies please, Call Bill at 609-965-4821

**Wanted 1971-72** - original front and rear fenders for a 360 C 8 speed also would like lights, also wanting an original large torpedo muffler for same. Call Bill at 609-965-4821

**1973 360 RT** - need an original muffler 609-965-4821

**Trade Husky Fork** assy. for a gas tank in good shape. Copies of Husqvarna literature John 315-331-6649.

**Wanted "Spare Parts Manual"** and "Shop Manual" for a '78 390 OR. "Husqvarna" tools for '78 390 OR. Contact Stan George SDG2650@aol.com

**87 Husqvarna 510** 4 stroke, 6 speed, water cooled, fresh rebuilt motor, brand new sprocket & chain, new tires, super nice condition, \$950 562-920-3447

**92 HUSQVARNA WXC360**, perfect cosmetically and mechanically, never been used \$1800 or b.o. - ask for Kevin - 310-813-4365

**84 HUSQVARNA 500XC** desert racer, 6-spd, new knobbies, spare piston & brakeshoes, excellent condition, vry low use, need to sell and very cheap at \$1000 (714) 970-7257

**1976 Husqvarna 360 GP ML** with great engine. Ready to race and only \$650 (714)256-0561

**2ea 73 Husqvarna 400's** have been sitting for 5yrs, ready to be worked on, & 1 74 Husqvarna 450 for parts, \$1000 all (909) 594-8119

**1973 Husqvarna 450** in excellent original condition. Call for details (818) 716-7928

**96 Husqvarna 610**, never been ridden, brand new, Custom exhaust, \$3400 714-990-0908

**90 Husqvarna 510** 4 stroke, street legal, nice condition, super clean, runs good, \$1800 or best offer (714) 832-8434

**1978 Husqvarna 360 GP** needs a little work but will sell for only \$150 (619) 656-6376

**1986 Husqvarna 250** needs work but only \$200 (760) 868-3177

**86 Husqvarna 430**, fresh paint, new plastic, brand new knobbies, excellent condition, only \$850 or best offer (805) 643-0833

**87 Husqvarna CR250**, water cooled, + spare bike & parts, many extras, looks & runs great, must sacrifice, \$700 (818) 343-8513

**1982 Husqvarna 390cc**, \$900 NEW TOP END. 1983 Husqvarna 430cc, \$1100 1984 Husqvarna 500cc, \$1300 They all have fresh tires. Steve (760)955-7223 or dangel@mscomm.com

**1974 Husqvarna 400 cr mx** totally restored AHRMA legal, all new mechanical parts through out, over \$3500 invested  
Email : mark.tracy@compaq.com Phone : (281)514-5404

**1976 Husky 360 XC**. Nearly new condition. Original everything. In storage for 20 years. Call Dan (205)424-8341  
Email : apeppercat@aol.com

**1988 Husqvarna WRK125 Enduro**, runs good, new ignition, chain, sprockets, rear tire, needs little work, good Project bike \$500 Call 860-399-5734 eve. 860-446-8286 days Paul or E-mail Peterr@snet.net for jpg photo.

**Misc assorted parts from two 82-85 husqvarna 250 dirt bikes**  
Email : husqvarna@aol.com Phone : 407-889-0902

**Husky CR250 mx forks**. Need space, will sell right! Email : scott@ltd.net Phone : 573-335-7684

**Husqvarna parts for sale** - Large quantity of NOS parts for Husky (pistons) and Maico (no plastic). Call or E-mail with needs. Part number helpful. 607.776.3204 after 7pm.  
Email : tpmcd@compuserve.com Phone : 315.455.4649

**Twin-Air/Hallman/Hi-Point Vintage MX Air Filters**. Available for most 1974-78CR/RM/YZ/KX/Can-am/Husqvarna, Montesa models. \$15.95 ea. Call. Email : scott@Ldd.net  
Phone : 573-335-7684

**Wanted 1972-74 Husky 450 BushMaster** any condition.  
Email : ddoorcy@ix.netcom.com Phone : 760-242-5504

**Needed Both side panels, Seat, Front and rear fenders, Plastics** around headlight for a 1983 Husqvarna 500 Cr Needed in good condition if not MINT Email : jessef@geocities.com  
Phone : 609-296-8532

**Wanted Husky WR 240 exhaust**  
Email : pmpwks@ozemail.com.au  
Phone : 03 94312255  
City : Eltham, State : Vi,  
Country : Australia

**Bill Kraus** has Husky parts for sale and trade in New Jersey Call him at 609-965-4821

**1978 250 CR** runs great after a total overhaul and chassis tuneup, cosmetics in good cond **MM02096** with engine 2065 2509 Call Todd in PA at 412-527-1160 make offer, need to sell.

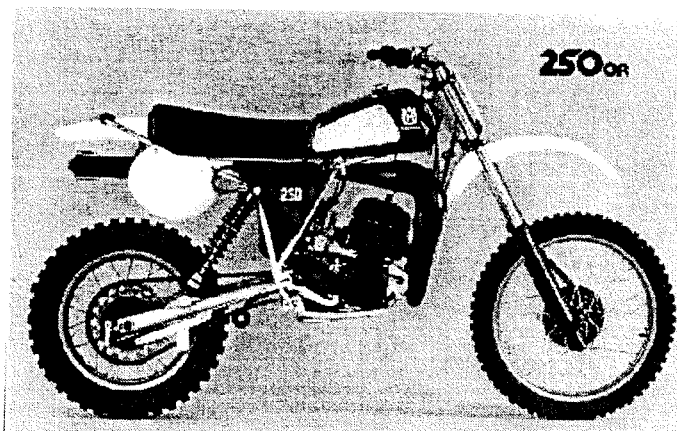

1979 Husqvarna 250 OR

**WANTED! Dead or Alive**

Söker min gamla kära Husqvarna 30 Sport årsm. 1953 ramnr 90527. Körbar 1970-talet. Gått på auktion 80-talet. Sen. kända äg. framlidne Folke Sund, Grängesberg. Urspr reg A 19708. Senast kända registrerad ägare undertecknad Jan Arvhult, Öknavägen 151 A, 632 39 Eskilstuna, S-Sweden Tfn & Fax Sweden 016-351484 ell mobil 010-2266558. E-mail; jan.arvhult@eskestuna.mail.telia.com

**RARE-71 400 8-spd-B.Aberg Replica**

**RARE-71 400 4 spd B.Aberg Replica** (rod out bottom of case) NICE-72 250wr-runs great completely restored to like new! 72 250cr -compl(crank brokeat flywheel end), 73 250wr -compl less carb 73 250wr-missing topend & bottom end froze upI also have a 70 360 8-spd. (mh)motor to put in 71 rolling chass(mi) Dennis E.Griffin-OKLA.CITY, OK 405-691-2520

**1995 Husky 360 WXC/WXE SALVAGED.**

All parts in good condition: engine, carb., airbox, subframe, electrical components, swingarm, r wheel assemble, rear caliper, rear brk pedal, rear shock, rear fender, lighting, FMF silencer+stk, gas tank, firt master cyl +lever, front right fork, new in the box husky fiber +steel drive clutchplates +springs. Everything \$1500.00 obo 614-855-9445 younger Tim Rooney (Ohio) TRooney519@aol.com

**Husqvarna 1967, 68, 69, 70, 71 and 5 speeds** for sale as a group or ? Contact Chip Howell at 619 445-5466 or e-mail chiph@cts.com all in excellent condition. **Collectors dream**

**Excellent copies of Husqvarna owners manuals, Parts Manuals, 1955-1975 \$20 +\$3 to ship** Call Craig 304 267-6471 Color copies of sales lit 1938-1997 call! Trades welcomed, some extra originals. Email - husky@intrepid.net

**Please send me your ads or ads from any source to share in the newsletter!**  
**Or send Husky tech tips, stories, events!**

**Past copies of Husqvarna Report Newsletters available ! \$3 will cover cost and mail in USA \$4 for all outside USA/Canada.**

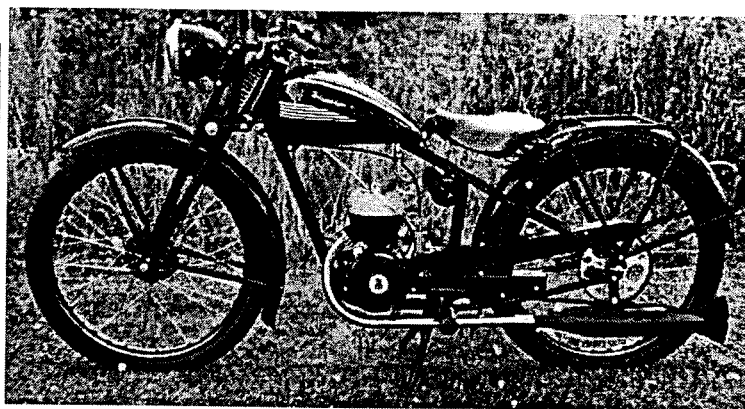
**Lennart Kraksberg's 1948 Husqvarna Modell 24 120cc**

**I'm looking for the 2 books- Art of Motocross by Jeff Smith and MR.MOTOCROSS by Torsten Hallman** hope i can find them in good shapeand they can email me at mitcho399@aol or call me at 310-838-9550 Mitch in LA,CA

**Husqvarna parts for sale, most years 1967-1987** buy, sell, trade , also have NOS Trelleborg tires for restoration call Forest Stahl in Indiana at 765-528-8356 Engine rebuilds, case welding, more

**I have just purchased a Husqvarna inventory** and I have most parts for Husqvarna 1967-1982. Todd Ameling in Ohio 419-639-2739. Call/ leave message. Engine rebuilding, restoration

**Terry's Husky in California** has a large NOS inventory and used items too! Call Terry Breitmaier in California at 209-369-1667 or e-mail at huskyguy@softcom.net

**Wanted - Husqvarna Dealer** sign-please contact David McKee in Texas e-mail dmckee@falcon.tamucc.edu or call 512/994-2676 work and home is 512/993-7323

**For sale parts off 1976 360 Auto**, engine 75.00, tank 20.00, forks 50.00. Engine number 2040 5285. Karl Knecht 817-262-2935 TX. E-mail kknecht@flash.net.

**For Sale: 1996 Husky 410**, mainly trail riding on bike, excellent condition, low hours, oil and filter changed after every ride. I am in VA, Must sell \$3,800.00 or best offer. **1996 Husky 125** for sale FMF pipe and silencer \$2,700. E-mail TSdog@aol.com. telephone number is (703) 444-2070 ask for Tim.

**1985 Husqvarna 500XC** - frame # XP03763, motor # 09920433, many new parts including aluminum clutch cover, complete PVL ignition system, air filter, brakes, fork seals, and piston ring. Very powerful, Ohlins single shock, liquid cooled. \$1500. Dubuque, IA. Phone (319) 557-7194 or e-mail Jeff at JC456789@aol.com.

**Husqvarna Model Numbers for Reference:**

YEAR	MODEL <sup>f</sup>	Frame No.	Engine No.	Notes
1972 1973 1973 1974 1974	125 CR,WR 125 CR 125 WR 125 CR 125 SC	MJ-0001 MK-0001 MK-0001 MK-1050 MK-10500	2022 xxxx 2022 2027 2035 2036	Silver forks, yellow tank, blue plates Betor forks, small muffler  Betor forks SC is for semi close
1975 1976 1977 1978 1979 1980	125 125 CR GP 125 CR GP 125 CR 125 CR,WR 125 CR	MK? ML-000 ML-16000 ML-22000 ML-31000 MN-1001	? 2039 2040 2040 2040 2040	
1981 1982 1982 1982 1983	125 CR 125 CR 125 WR 125 XC 125 CR	CN-1001 CN-11000 WN-11000 XN-11000 CO-00001	2040 2040 2069 2040 2093	
1983 1983	125 WR 125 XC	WO-00001 XO-00001	2093 2093	
1974 1975-76 1983 1983	175 WR 175 GP 175 WR 175 XC	MK-0001 ML-00001 WO-00001 XO-00001	2036 xxxx 2041 2064 2064	Blue tank
1965 1966 1967 1967 1968 1968 1969 1970  1971 1972 1972 1973 1973	250 Works Motocross 250 Works Motocross 250 Husky 250T Commando 250 Husky 250T Commando 250 cross 250 cross  250 cross 250 CR 250 WR 250 RT 250 CR	65001 66001 670001 167001 MF-0001 168xxx MG-0001 MH-0001  MI-0001 MJ-0001 MJ-0001 SK-0001 MK-00001	65xxx 66xxx 67xxxx 167001 25xxxx 168xxx 25xxxx 25xxxx  2xxxxx 2018 2019 2026 2028 xxxx	Engine numbers 65-67Husqvarna match frame. 250T also match. MF series 250 engines started with 250xxx and kept increasing from that point to 251xxx, then 252xxx thru out 68, 69, 70, 71 and did not match frame. 6 port 250 design intro in 69  Street legal, lites, horn, turn indicators Small steel tank, w/white plastic,black frks
1973 1974 1974 1975 1975	250 WR 250 CR 250 WR 250 CR GP Mikkola 250 WR	MK-00001 MK-10500 MK-10500 ML-0001 MK-10500	2032 xxxx 2033 2037 2042 2043	Regular steel tank, aluminum fenders The "Mag 250"  Gold Mikkola decal Fwd shock swing arm
1976 1976 1977 1977 1978	250 CR 250WR 250CR 250 WR 250CR	ML-6000 ML-6000 ML-16000 ML-16000 ML-22000	2042 2051 2059 2060 2065 xxxx	

1978	250WR	ML-22000	2066xxxx	
1978	250OR	ML-22000	2066	
1979	250CR	MM-00001	2065	
1979	250WR	MM-00001	2066	
1979	250OR	MM-00001		
1980	250CR	MN-1001	2081	
1980	250WR	MN-1001	2088	
1980	250OR	MN-1001	2080	
1981	250CR	CN-1001	2079	
1981	250WR	WN-1001	2083	
1981	250XC	XN-1001	2081	
1982	250CR	CN-11000	2088xxxx	
1982	250WR	WN11000	2089	
1982	250XC	XN-11000	2089	
1982	250MP	AM-0001	2087	
1083	250CR	CO-00001	2088	
1983	250WR	WO-00001	2089	
1983	250XC	XO-00001	2089	
1966	360 Motocross	669xx	669xx	50 produced in 1966 total, 10 imported
1967	360 Viking	670001	67xxxx	Last year for bolt together
1968	360 Viking	MF-0001	36xxxx	Welded frame, new black hub later models
1969	360 cross	MG-0001	36xxxxM	
1969	360C Sportsman	SG -001	36xxxxS	Early big tank, cases stamped S, lites+
1970	360 cross	MH-0001	36xxxxM	8 near eng # would designate 8 speed.
1970	360C Sportsman	SH-001	36xxxxS	Big tab tank, lites, speedo
1971	360 cross	MI - 0001	3xxxxxM	8 near eng # would designate 8 speed.
1971	360C Enduro	SI - 0001	3xxxxxS	BIG tab tank, lites, speedo
1972	360C Enduro	SI -1800	37xxxxS	Full collar DM tank w/center cap
1973	360WR RT	SK-0001	2023xxxx	street legal w/turn indicators,horn
1975	360CR GP	ML-0001	2045	
1976	360CR GP	ML-6000	2055	
1976	360WR	ML-6000	2052	
1976	360 Auto	ML-6000	2053	first year automatic
1977	360 WR	ML - 15000	2052xxxx	
1977	360 Auto	ML - 16000	2053	Automatic
1977	390CR	ML-16000	2061	
1978	390CR	ML-220000	2061	
1978	390WR	ML-220000	2062	
1978	390OR	ML-220000	2067	
1978	390 AMX	ML-220000	2070	Automatic Motocross
1979	390CR	MM-00001	2061	
1979	390WR	MM-00001	2062	
1979	390OR	MM-00001	2067	
1979	390ACC	MM-00001	?	Automatic

**Husqvarna 1974 Mag 250 for sale by my neighbor. Might trade for old sports car!  
Call Jim in Oregon at 541-482-8159 He may have parts also!**

1980	390CR	MN-1001	2080xxxx	Automatic
1980	390WR	MN-1001	2084	
1980	390OR	MN-1001	2080	
1980	390ACC	MN-1001	2077	
1969	400 cross	MG-0001	400xxx	possible 8 speed if marked Tab tank, early models had 32 sidefloat Full collar tank w/center cap
1970	400 cross	MH-0001	40xxxx	
1971	400 cross	MI-0001	4xxxxx	
1972	400 CR	MJ-0001	2025	Reg tank with aluminum fenders Sm maroon tank with white plastic
1973	400 CR	MK-0001	2030	
1974	400 CR	MK-10500	2030xxxx	New logo, big white air box 6 speed trans Fwd shock swing arm
1974	400 WR	MK-10500	2038	
1975	400 WR	MK-19500	2048	
1981-82	420 AE	WN-1001	2085xxxx	
1981-82	420 AXC	CN- 1001	2085	
1981	430 CR	CN-1001	2086	
1981	430 WR	WN-1001	2087	
1981	430 XC	XN-1001	2087	
1982	430 CR	CN-11000	2086xxxx	
1982	430 WR	WN-11000	2087	
1982	430 XC	XN-11000	2087	
1983	430 WR	WO-00001	2087xxxx	
1972	450 CR	MJ-0001		
1972	450 WR	MJ-0001		
1973	450 CR	MK-0001	2021xxxx	
1973	450 WR	MK-0001	2024	
1974	450 CR	MK-10500	2034	
1974	450 WR	MK-10500	2031	
1975	460	MK-	2034	
1982	500 CR	CN-19001	2094	
1983	500 CR	CO-1001	2094	
1983	500 XC	XO-1001	2094	
1983	500 TC	CO-10001	2095	
1983	510 TE	WO-10001	2095	
1983	510 TX	XO-10001	2095	

This listing is not 100% correct! It is a great guide and fits most peoples' needs. I would like feedback/corrections!

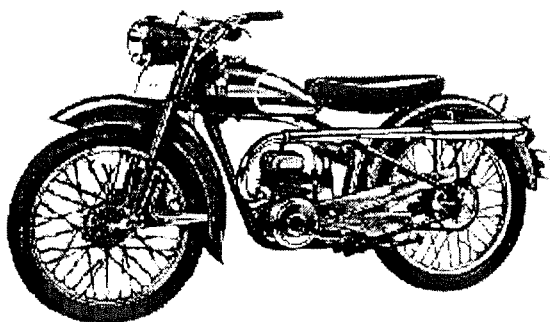

1955 Modell 31 Sport

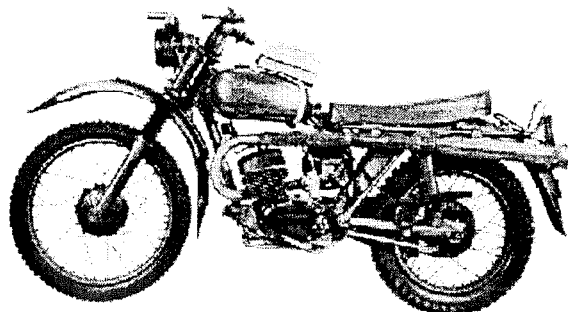

1967 250A Swedish Army Mc



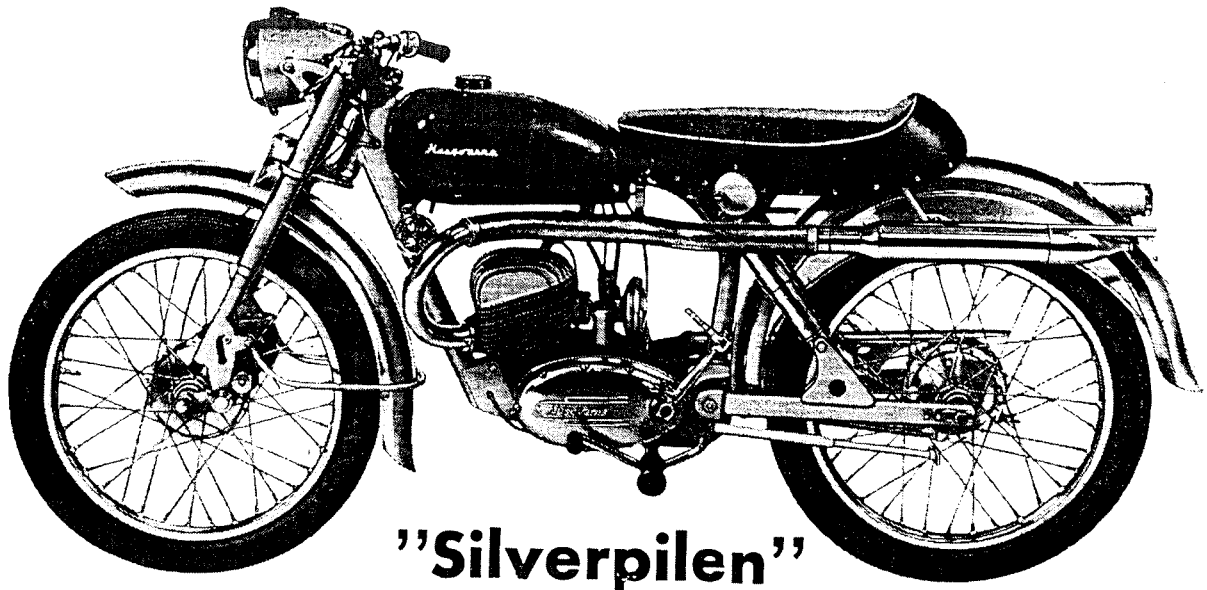

## "Silverpilen"

### Specifikation:

Motor:	Husqvarna 175 cc 2-taktsmotor, vändspolssystem. Effekt 9 hk vid 6.000 varv/min. Lättmetallcylinder med hårdförkromat cylinderlopp. Avtagbart cylinderlock av lättmetall. Vevaxeln lagrad i dubbla oljesmorda kullager, vevstaken i rullager.	Parkeringsställ:	Sidostöd.
Växellådan:	Med motorn sammanbyggd halvautomatisk växellåda, innehållande 3 växlar samt friläge. Utväxling: ettan 18,8: 1, tvåan 10,4: 1, trean 7,2: 1.	Styre:	TT-modell.
Förgasare	Dubbelförgasare Bing 18/17/5.	Stödlås:	Inbyggt stödlås vid styrhuvudet.
Tändning:	Svänghjulsmagnet.	Belysning:	Strömlinjeformad strålkastare, 6 volt 25 watt. El. signalhorn.
Ram:	Öppen ramkonstruktion uppbyggd av krom-molybdenrör.	Hastighetsmätare:	Inbyggd i strålkastaren och driven från växellådan.
Gaffel:	Moderniserad swinggaffel av HVA:s välkända modell.	Ljuddämpare:	Uppdraget avgasrör med isärtagbar ljuddämpare av sportmodell.
Bakhjulsfjädring:	Svängarmar med oljedämpade fjäderben.	Sadel:	TT-modell av galonklätt skumgummi.
Bromsar:	Bromstrumdiameter 140 mm bredd, 20 mm både fram och bak.	Verktygslåda:	Inbyggd i sadelstommen.
Nav:	Husqvarna av lättmetall. SKF kullager.	Kedjeskydd:	Av hlankolerad aluminiumlåt som skyddar både övre och nedre kedjeparten.
Skärmar:	Polerad lättmetall, skärmstag av stålrör.	Hjul:	Fältnar av högglanspolerad lättmetall WM 1-19.
Bensintank:	TT-typ av stålplåt, rymd 7 liter.	Gummiutrustning:	Trelleborg 2.75×19" 2-lagsdäck fram, 3.00×19" 2-lagsdäck bak.
		Topp hastighet:	Ca 100 km/tim.
		Tjänstevikt:	75 kg.

**Riktpris Kr. 2175:—**

# - en hårding i "lätta" klassen



HUSQVARNA VAPENFABRIKS AB • HUSQVARNA

# SERVICE BULLETIN



one of three

TO: ALL HUSQVARNA DEALERS  
FROM: HUSQVARNA SERVICE DEPARTMENT  
DATE: FEBRUARY 1, 1979  
RE: 250 CR, OR, WR TUNING SPECIFICATIONS

With these modifications performed (all or in part) the engine is working on a higher performance level and a reduced safety margin.

It is therefore important to increase the inspection intervals on the piston, cylinder and lower end.

NOTE: Any modification on the engine voids all right to warranty.

- Fig 1: Modify exhaustport as shown, make sure that no metal is removed in the upper corners of the port.
- Fig 2: Remove some metal and smooth the entrance of the transferport, where the arrow points.
- Fig 3: Modify the front piece of the reedvalve holder (16-10-357-01) as enlargement shows.
- Fig 4: Sharpen the dividing wall between the main and auxiliary transferport.
- Fig 5: Raise and widen the two piston slots as the left figure shows. Figure at right shows the approximate upper angle of a slot when modified.
- Fig 6: Add 50mm (2.0 inches) to the exhaust pipe as figure shows. NOTE: This only applies when the exhaust pipe has not been modified by the factory.

8-059

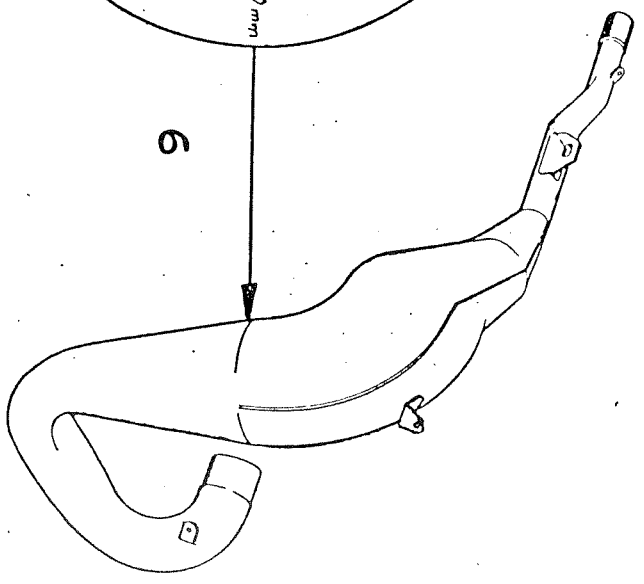
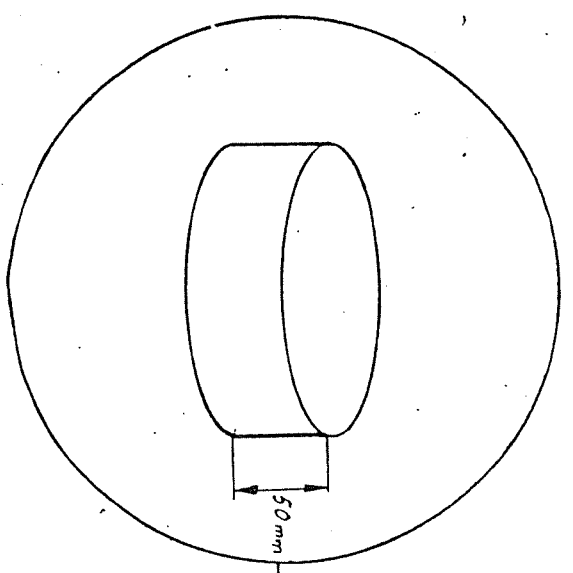
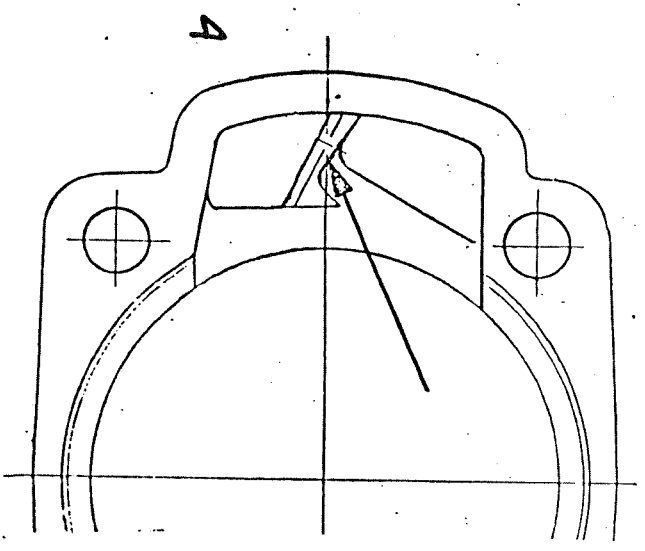
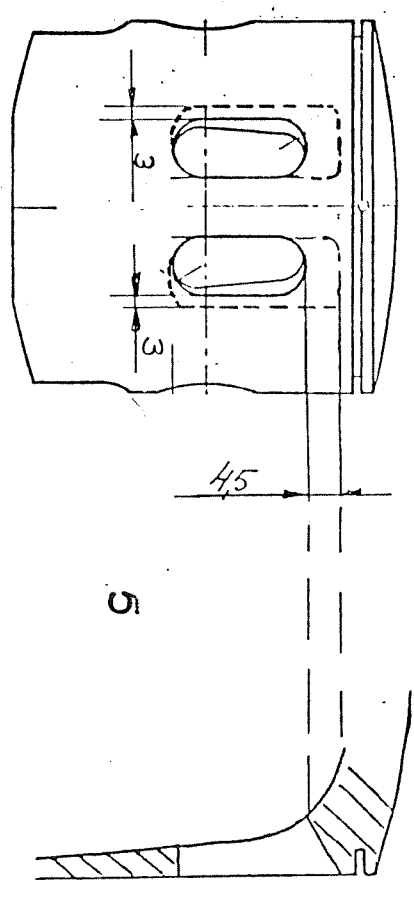
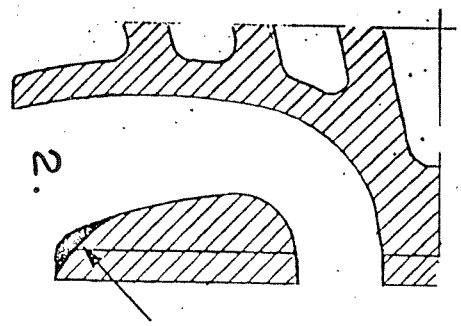
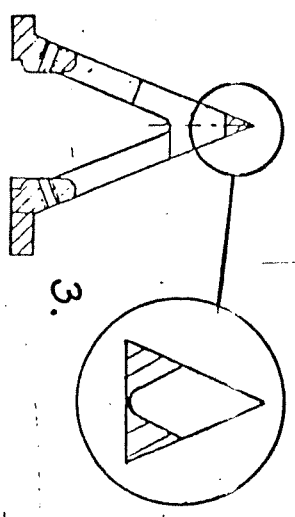
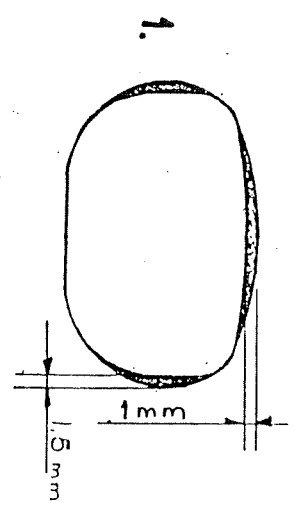

# CHEMICAL PLATING CORPORATION

~ electroless plating systems ~

Complete and professional plating systems developed specially for D.I.Y. enthusiasts, hobbyists, restorers and small workshops.

## DO YOUR OWN PLATING

**Industry proven plating process - ELECTROLESS NICKEL PLATING - IDEAL FOR OFF-ROAD BIKES**

- extra-hard-wearing and super-corrosion-resistant
- latest matt-satin finish for general fasteners etc or mirror-shiny, bright nickel finish for decorative parts
- also plates inside hollow tubes and complex shapes !
- even plating everywhere - to any thickness required
- provides a top-quality plated finish - quickly and easily !

★ *no more lost parts - no waiting !!*

COMPLETE PLATING SYSTEMS FROM ONLY \$99  
- direct from manufacturer -

FREE Information Brochure and Plated Samples

TEL / FAX : (954) 344 3592

PO BOX 771364 CORAL SPRINGS FLORIDA 33077

E-MAIL : chem-plate-corp@msn.com

# Hall's Husqvarna

Largest inventory of Husqvarna Parts for Vintage, Evo and Modern in Stock!

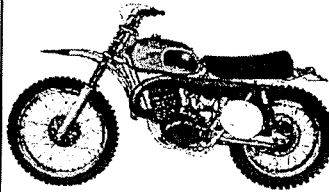

Also a Large Inventory of Cagiva Parts.

25 years experience in sales and service.

Parts Shipped Daily via UPS

VISA-MASTERCARD-DISCOVER

3801 N Dirksen Pkwy

Springfield, IL 62707

Phone 217-789-0107

FAX 217-789-7408

Talk to Raymond!

Talk to Jay Hall !

Hours:

Closed Sun/ Mon

Tuesday 9-7

Wednesday 9-6

Thursday 9-6

Friday 9-7

Saturday 9-5

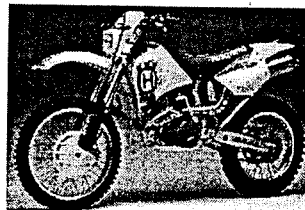

# VINTAGE HUSKY

Reproduction Parts-N.O.S. Parts

Complete Restorations

Race Ready Motorcycles

Bike Rentals

Complete Engine Rebuilding

Painting - Gas Tanks - Frames

Decals - Stickers

Complete Suspension Work

Machining Done In-House

Welding - Fabricating

Trelleborg Tires

We Do Everything

When It Comes To Your

Husqvarna Motorcycle

760-744-8052

Progressive Suspension Dealer  
Shocks & Fork Springs



155 Balboa St. D-2 San Marcos, CA 92069

# Will Stoner

Vintage Swap Meets

*Ninth Season 97-98*

NOV 9 ...Mansfield OH

JAN 18 .....York, PA

FEB 15...Mansfield,OH

APRIL 5 .....York,PA

Bring your show bike!

Spaces \$50 all inside

9-3 with 150 vendors

Food and fun for all!

Call 440-543-0632

# OLD MOTORCYCLES WANTED

Husqvarna Bikes, Parts, Literature '03-'74

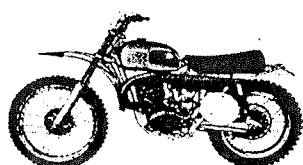

Craig Comontofski  
1501 W. King St.

Martinsburg, WV 25401

(304)267-6471

Marge Stahl

Res. 759-4805

Forest Stahl

Res. 759-4805

**Advance**  
**TOOL & DIE CO.,**  
**INC.**

Manufacturing of Precision Tools,  
Dies, Jigs, Fixtures, Gauges and Special Equipment

1700 S. Nebo Rd. - 400W  
Yorktown, IN 47396

317-284-7653