

# Husqvarna Report

motorcycle club

19<sup>th</sup> Newsletter for the Husqvarna Motorcycle Club for info e-mail [husky@intrepid.net](mailto:husky@intrepid.net) or see <http://www.intrepid.net/~husky/hustest.html>

## Kent Captures California



**Kent Howerton blasts a berm at Glen Helen Vintage Iron National June 2000 with a modified Mag 250**

### Contents of this issue:

Kent Howerton rides again!.....1	1982 Parts List, Plastic + Airbox.....12	<b>Back issues of the Husky Club newsletter</b> are available at \$3 each, ppd.
Lion Yellow Paint Formula.....3	1985 400 WRX Sales lit.....14	Send check or money order payable to
Husky Tank Restoration .....4	Öhlins Single Shock -part 3 of 3 .....15	Craig Comontofski.
Husky Tank Pattern.....5	Husqvarna Logos .....17	And mail to : 1501 West King Street,
Dick Burluson rider card.....5	Wiring Diagram 73-75 250/360 RT.....18	Martinsburg, WV 25401-2001
MegaClassifieds./Suppliers.....6	Aluminum Swing Arms.....19	for more info e-mail: <a href="mailto:husky@intrepid.net">husky@intrepid.net</a>
	Husqvarna Suppliers.....20	

### Vintage Iron World Championships, Glen Helen Raceway , June 24&25, 2000, By Harvey Mushman

In it's 3rd year of existence, the Vintage Iron World Championships has become THE place to be if you race Vintage Motorcycles. This year Promoter Rick Doughty of Vintage Iron added a "Yamaha Race of Champions" race to the now 2 day event. This race pitted former Yamaha factory riders against each other in a 3 moto format where each rider rode a 2000 Yamaha 125,250 and

a 426. Attending this prestigious event where Mike Bell, Broc Glover, Tim Hart, Marty Moates, Gary Jones, Jim Holley, Rex Staten, Danny LaPorte, Bruce McDougal and Multi-World Roadrace Champ Eddie Lawson. In addition to the stellar list of riders was an equally stellar list of sponsors- Yamaha, Edge Sports, Cycle News, Oakley, White Bros, No Fear, Motion Pro, EZ-Up, VP Fuels, Maxima, Sudco, Works Performance and Speedvision.

Saturday had scheduled Vintage Classes with Evolution support

classes. When the gate dropped for the 1st 500 Expert moto, Kent Howerton blasted his "Team Coolband" Husky to the front followed by Vintage Husky's Tim Nash, Maico mounted Dan Berg and Evo Sport's Rick Humphreys. Nash had the course wired and passed Howerton on the jump filled front straight on lap 2 only to have Howerton power up the inside in the next corner. As the 2 Husky riders pulled away Berg had his hands full with another Husky rider, Steve Parker. Parker was flying thru the pack after a poor start. Humphreys was going backwards and was fighting with Arizona's Ed Zornes over 6th. As the laps wore on Howerton and Nash changed positions 2 to 3 times a lap. Kent said, "I had a couple spots where I was faster than him so I waited for the last lap, but we didn't get the white flag-only the checkers." Kent continued, "I've only got 5 laps of practice on the Husky. John LeFevre at Vintage Husky builds an incredible bike, as fast as any factory bike I rode back in the 70's. I'll get Nash the next moto." Howerton was true to his word; the gate dropped and he was gone. This time Nash had to fight Dan Berg for 2nd. While Howerton was doing massive whips and cross-ups, Berg had gotten the better of a very tired Nash and took 2nd followed by Zornes and Charlie Beck. Humphreys had a chain come off and could only manage an 8th.

In the 500 Amateur division "Mr CoolBand" himself Buddy Lavin battled both motos and ran a consistant 6-5 for 5th in a heavily contested class. One of the biggest classes of the day was the Pre-75 +40 class. Unlike years past where riders could ride any year bike in the age classes, this year everyone was limited to Pre 75 models. It didn't matter what anyone rode because Howerton killed 'em. Grabbing the 1st moto holeshot was Evo Sports' Rick Humphreys followed by Howerton and Billy Grossi. Team Texas was livin' large - three of their riders out front. The Rhinestone Cowboy was having fun, using his patented "Double-Clutch" blowing up berms and launching his Husky clearing numerous 75+ foot plateaus all crossed up with ease. Kent's only competition was "Texan for a day" Billy Grossi, who was aboard a very fast Vintage Husky prepped 74 CR400. (Buddy Lavin stepped in to offer Billy a bike to ride when his CZ got a flat). Billy looked comfortable on the big bore and kept Kent honest for 3 laps, staying on his tail. Humphreys was out again with a derailed chain. Coming up from a slow start was Team Honda's Rich Eierstedt aboard a 74 CR250 Honda Rich could only work up to 3rd by the flag.

The 2nd +40 moto had Kent out front again with Arizona's Ed Zornes, Grossi and Humphreys. Grossi dispatched Zornes and closed on Howerton. Kent saw his former adversary closing and kicked up the pace pulling to a 4 second lead that held to the finish. 3rd went to Zornes. Houston's Jeff Bintliff, riding a Diamond Don tuned CZ 400 went 3-3 for 2nd overall in a huge Amateur class. The 250 Experts were up next and "The Texas Tornado" Steve Wise was 2nd into the 1st corner. Wise looked like artist as he carved his way around course. After 2 laps Steve's 7 Handicap came into play and Steve wisely eased off and settled for 3rd in both motos. Vintage Husky's Tim Nash took the double moto win. "I'll be back next year and I'll be better prepared. Can I get one of those Huskies?" asked Wise. "I only have 3 trophy's in my house This plaque will be along side the Supercross,Roadrace and Dirt Track trophies for sure. I had a blast!" Steve said. Trip organizer "Diamond" Don Rainey battled John DeSoto each moto before crashes took him out of the lead pack and salvaged a 5-5 for 5th. Floridian turned Texan Fred Lasseter rode both Vintage and Evo, which is very tough to do and won both the +50 Am and Evo 3 Am classes.

Sunday was for Evolution bikes plus the MotoCross Des Nations event. There were Teams from England, Italy-I, Italy-II,

Arizona, Texas, Kansas, Ohio and a team from Series Sponsor "The Edge Sports" all lined up for Honor and Glory. Motocross Action, Dirt Bike, Cycle News and SpeedVision were there, and this was a chance to show your stuff. With 16 Evolution and 8 Vintage bikes, it would take a calculator to figure the points. Vintage bikes earn single points according to their finishing position and Evo bike have their finishing score doubled. Moto 1 had 4-Stroke Nat'l competitor Robert Naughton (Az) aboard a 490 Maico out front followed by 80 YZ250 mounted Robert Little (Edge), 80 RM400 mounted Mike Halpin (Az) and 1974 Husky mounted Kent Howerton. Kent blew by Halpin, tried to rail the outside berm by Little, lost the front-end and went down hard. Kent got up, dusted himself off, checked the bike over straightened the front forks then took off. This guy didn't win 3 Nat'l titles because he couldn't come from behind. The former factory Husky,Suzuki and Kawasaki rider put on a riding clinic that had everyone taking notes. Naughton took the checkers followed by Edge Sports team-mates Andy Anaya on a 82 YZ 490 and Robert Little on a 80 YZ250. Howerton crossed the line in 7th. Humphreys was 9th and Wise 13th. The 1st moto points total showed Arizona in 1st with 12,5,1 finishes for 24 points, Texas 2nd with 7,9,13 finishes for 29 points and Italy-I in 3rd earning 8,6,4 finishes for 36 points. Team Texas knew that Kent needed to finish in the top 3 and Hump and Wise needed to improve by at least one position each. When the 2nd moto left Naughton / )was again in front followed by Ted Mink (Oh) on a 81 YZ465, Howerton and YZ250 mounted Robert Little(Edge). With-in 1 lap Kent had passed Mink and actually closed on Naughton. The Maico rider could see Howerton was getting close so he turned up the pace and pulled out a safe cushion. Mean while Little couldn't bear to get beat by a "Vintage " bike and worked on Kent finally squeezing by on lap 4. Midpack was where the Gold Medal would be decided. Humphreys was 10th and Wise was 13th, while Arizona's Zorne and Halpin were 7th and 4th. One of the Texas riders needed to beat Zorne. It wasn't to be. Everyone held positions and Team Arizona won the Gold. A Texas sized thanks to Buddy Lavin and Mark Liebermann of CoolBand for the T-shirts, decals and very cool Jerseys, Vintage Husky for the bike prep and maintenance, Evo-Sports for the idea and Diamond Don Racing for transporting the bikes while everyone else flew. A Big hug to Francene DePrez for taking the photos and cooking the BarB-Q and Dr. Rick Hill for being the driving force behind this effort.

#### Team Texas Results :

Kent Howerton	Pre 75 500 Exp	2-1 = 1st
	Pre 75 +40 Exp	1-1 = 1st
Steve Wise	Pre 75 250 Exp	3-3 = 3rd
Billy Grossi	Pre 75 +40 Exp	2-2 = 2nd
Buddy Lavin	Pre-75 500 Am	6-5 = 5th
Don Rainey	Pre 75 +50 Exp	5-5 = 5th
Jeff Bintliff	Pre 75 +40 Am	3-3 = 2nd
Rick Humphreys	Pre 75 500 Exp	6-8 = 7th
	Pre 75 +40 Exp	DNF-5 = 7th
Fred Lasseter	Pre 75 +50 Am	1-1 = 1st
	Evo-3 Am	2-2 = 1st

#### MotoCross Des Nations

Team Texas	2nd Overall
Kent Howerton	7-3
Steve Wise	13-13
Rick Humphreys	9-10

# Paint Formula

## 72-78 Husky 125 - Lion Yellow

by Craig Comontofski

I know it has been a while since our last paint formula , but sometimes it takes while to get good matches. I picked up a NOS 125 Tank last month and this is my current computer , actually Dupont ChromaColor color scan/match for Lion Yellow .

How this thing works, as I am told by my nice , but not so technical Paint techs at the store I deal with is, the computer scans the color, then reviews it's files and comes up with the closest standard formula , say Jaguar yellow , and then makes a variation on that formula.

This formula is based on :

Jaguar Yellow , 1995, Code: JUC29, Alt:CF01

881J HS YELLO OXIDE	119.8
801J HS WHITE	56.5
07J LS BLACK	1.6
884J LS RED OXIDE	1.6
150K B/C BALANCER	259.5
175K BINDER	44.2
Total -----	483.2 grams

This is the weight formula for a pint can of Basecoat. Let me repeat this is not Jaguar yellow, but a custom formula based on Jaguar yellow.

This formula is only good for B/C Dupont paints, so please don't run down to your PPG or RM dealer and want this converted or mixed

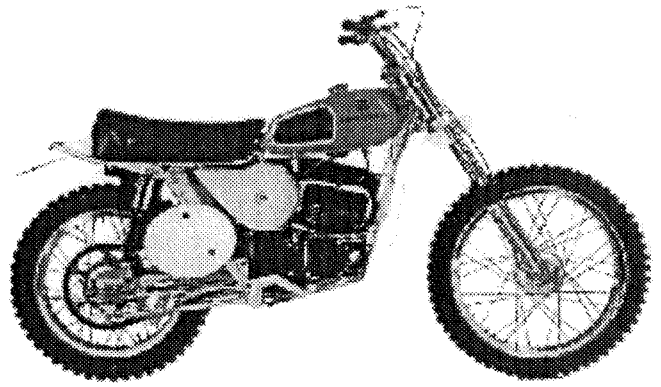

The stated price for this pint of Dupont Basecolor is \$25.10, but you still need activators, clearcoat , activators, primers, thinners, convertors and such.

As I have stated in the past, it would be best to put the base coat color, Lion Yellow or any any other base coat, over a white primer or sealer, not gray, not light gray, not red, not yellow, not green, .....white. The decal on this tank is early font -

**Husqvarna** in solid black, the stripe is white, no logo (see newsletter#16) for the Huskys of 72-73. And then 74-77 125 Huskys use a dark blue , gunsite logo with plain font

**Husqvarna** also in dark blue.

Next issue - Husqvarna Maroon - 1973-75 or Husqvarna Orange 72-75.

I need help with Auto Green 76-79, 175 Blue 75-76, 125 Blue 79-80, Desert Master Yellow 72-75, and possibly others. I would like to purchase NOS tanks in these colors to keep in a historical collection, any help?

Once the patterns are taped off , the general distance across the backbone of the tank from tapeline left to tapeline right, in the center of the front to back (just eyeball this), is about 5.75". The tank gets wider from front to rear so this is a guide. I measure about 5.25" at the rear and 6.5" at front when I do this quick backbone check with with a flexible tape. Make it look good on far view, stand back , hold your thumb up , look artistic.

# Husqvarna Tank Restorations

- A Reflection of Total Quality

Is there any part on vintage competition bike that reflects its image or image of quality as much as the fuel tank? Or even any modern competition bike's graphics? Sure the quality of all the other components like the wheels, seat, engine finish, exhaust, number plates, etc. will add or detract from the feeling of a well maintained machine, but I think the fuel tank stands out in my warped mind, as the obvious check on overall quality. Put a Maico tank on a Husky and, at first, it will look like a Maico. Put a bad looking Husky tank on a nice Husky and at first it looks like a very poorly maintained Husky. Anyway my point is that nothing looks better and makes the owner feel prouder than a great paint job on his/her Husqvarna motorcycle gas tank.

Maybe I am a Husqvarna snob, but nothing gets me chuckling more than to see a picture of past Husky heros standing next to a vintage Husky with a paint job that is so far from original it makes me cringe. Wrong chrome area, wrong paint color, wrong decals....yeow ! What was the owner thinking? Chrome area on sides "I think they were like this", "paint it red , all Huskys are red" ....close enough? Ouch! Kinda like painting your 365GTB/4 Daytona with metal flake red.

In a effort to help improve the restoration of our early Huskys, I have included the patterns for chrome sides on Husqvarna gas tanks for the CR models 73-74 , the small steel tank. It is also 125 72-74. It may be appropriate for 75 -76 as well , but I am not sure based on the advertising lit from those years. These patterns are not correct for slightly larger WR tanks only CR tanks.

*How I have used patterns of this type have been:*

**Technique #1** - cut out pattern 1/8" smaller, cut hole in center of pattern (like a 1" hole, maybe a couple)to allow taping pattern to side tank for positioning, tape around edge maintaining 1/8" tape line.

**Technique #2** - Use a piece of glass about 12" square, place full size pattern underneath, tape glass to table top, so that the glass and pattern will not shift. Cut slightly smaller (3/16") filler panel from heavy paper and tape to center of pattern(seeing it thru the glass) using hole technique like above. Masking tape around pattern looking thru glass to maintain exact line. Lift pattern from glass, place on tank, align, press in place.

*I am sure there are better techniques - please you guys write/call me about them. husky@intrepid.net*

As the tank curvature is more pronounced on 66-71 Husky tanks, it is a little more of a challenge. I will try and share my techniques for these in future issues, as well most of the 77-82 patterns.

The decal **placement** on Husqvarna gas tanks is actually different for every single year from 66 thru 82 .

The **font** of the **Husqvarna** decal is different in different eras - 66, 67-71, 72-73, 74, 75-76.

The **gunsite logo** is different **size** for different eras - 74, 75-76, 77-80.

The tank white **stripe width** around the chrome panel is different for different eras 66-71, 72-76, 77-80.

The **chrome panels** are different **sizes/shapes** for most years 66-82.

# Husqvarna

Full Size Chrome panel pattern for 125 Husky. Just cut this out, and use as a pattern for taping off your chrome panel! Also same as any small, steel tank 73 thru 76, 125 thru 400. Your white pinstripe will be right down the middle of this pattern outline. The white stripe is 6mm or 1/4 " in width



**TEAM**  
Husqvarna

**Dick Burleson**

## Mega-Classifieds #19

**\*One 1984 N.O.S. seat cover**, blue, part # 15-13-578-01 still in plastic bag \$45 + ship. **\*two N.O.S. white plastic "MALCOLM SMITH" gas tanks**, 4 gal. fits all models 1981-1984 \$40 + ship **\*one N.O.S. SEM ignition. stator only**, no flywheel. dual lighting coil. fits 1981-1988. \$200 + ship **\*e-mail - kikiwi@uswest.net or 480-473-4713 in AZ. Phillip**

Wanted - **Motoplat ignition for 1977 125CR** - call John in AZ at 520-692-9554 or e-mail mallory@ctaz.com

**85-86 , 4.5 gallon desert tank**, never been used , never any gas, \$125 firm - call bradley at 540-656-1896 or e-mail rbranch4@excite.com

**I bought a 1973 250 WR.** The parts I recieved with the bike are: footpegs in near perfect condition, the spark plug / axle /steering head wrench, countershaft sprockets in 11, <3>13, 14, 15 tooth, a Bing carb #1/36/106. All parts are very good to new. The original footpegs show very little use and would be good for someone's restoration project..... The parts I am in need of are: cylinder and/or liner, piston and ring<s>, intake manifold, air cleaner and cover, front brake cable, and rear shocks. The engine # is 2032-0306. I would like to buy/sell/trade any of this. Thank you for your time. Dave Dillon...e-mail davesd\_97060@yahoo.com ...Ph.503-674-5128 Troutdale, Oregon

**1973 Husqvarna 175 /** This is a non cataloged version of the 125. Everything is the same except the piston is larger. The bike has sat in a basement most of its life and is in great condition. New parts include: Fenders, front, rear and inner rear, Barum rear tire, Kenda front, Gasser throttle and cable, front brake cable, seat cover, chain. The bike is a great rider and good starter. The gas tank has no paint but is dent free. Pictures are available. Shipping by Forward Air or will deliver fairly close to Indianapolis. \$1300.00 John Heger 317-843-0027 jsh56@aol.com

**1982 Husky 500CR 4 spd.** Very stock except for 40mm Mikuni replacing stock 44mm, and a JT front number plate. Can ship forward air. \$1250.00. Rich 914.942.5301 or rf145@aol.com

Wanted; clutch parts for 1981 430 CR contact Bruce at kriter58@yahoo.com

Wanted - **1981 original owners manual**, parts, manual, and service manual, call Merritt, weekends, 845-692-2325, pls keep trying ! Thanks

Wanted - **parts for MI 400** cross 8 spd - contact Tom Reeves, 4105 Kings Rd, Bismark, MO 63624

Thanks to Marty Boggess for the refrigerator magnet - Craig

**Huskys: 3ea 250's, 73-74, 1 WR, 2CR**, these are excellent parts bikes, easily made into 2 running bikes - \$800 takes 3. Also one MI frame , half cases for 250 4 speed, primary cover, trans parts , etc - make offer Call Paul 440-988-7160

Wanted - **1987 510 cc (water-cooled)** Husky plastic, plastic, plastic, including gas tank with Husky stickers. Also interested in a spare seat, I am getting mine recovered and need a spare - e-mail - ltkelly@us.ibm.com or call 303-665-8300

**1970 Husky MH 400** nice condition, org bars, org tank, plastic fenders, MH 2755, M401771 \$1200 obo call Mark at 319-277-8016

NOS Husky cases - center cases for 77-81 250. Double lug front motor mounts w/nos clutch cover and ignition cover \$500 or will separate 216-486-9075

NOS Husky Ohlins shocks - for 1980 Husky part number 15 10 804-02 with springs, remote reservoir type. Marked with HU-03-7. 17 1/8" eye to eye. Heims on both ends. \$475/pr. Call Rick

216-486-9075

Dick Buleson Poster - National Enduro Champ, 1974-1982 autographed 24x36, Dick riding a 1977 wr Husky, B+W, E.C. - 216-486-9075

LN Husky Tanks - In take offs - red 1975 GP style \$175, black 390 CR style \$150, NOS 390 auto alloy green \$300, also 81-82 black tanks \$75-\$100 call 216-486-9075

nos Husky ND speedo - \$100 part number 15 17 493-03, 0-85 mph, 0-140kph call 216-486-9075

nos Husky rod kit - 16 10 642-01 \$160 - call 216-486-9075

'87 500XC w/ seized engine. otherwise good condition, some extra parts. looking for replacement engine, or sell as project/parts bike. located on central coast of CA. Delivery in CA may be available. please contact me with any questions. Looking for a reasonable offer. RyanHollowell@hotmail.com (805)783-1033

Wanted: parts for 82 Husky WR 250. NOS front and rear fenders, fuel tank (blue and aluminum), seat cover, km odo drive and really any parts you may have in new or very good shape for this bike (especially wear items: brakes, pistons, sprockets etc..) Phone Misha at 416-259-5423 or email me at subo@idirect.com

**I have a 1981 Husqvarna CR430** in fairly good condition w/ over \$1000 worth of parts including: 2 extra frames, 4 extra wheels, 3 extra tires, extra set of dual spring rear shocks, 2 extra sets of forks, extra set of handlebars(maybe 2), extra jugs, many extra tranny parts, 2 extra seats, 3 extra gas tanks, nearly complete tool kit, this bike was raced Cross-Country in it's day so I have many racing accessories, and a brand new set of Moose handguards that have never been used. These are only the parts that I can think of off the top of my head, so if you are interested I will make a list. I would like to sell it as a package deal but I might just sell parts. Best Offer "Dale Randall" <daler@uslink.net>

Wanted: ML model front and rear fenders to fit 79 125CR. (The bike has a blue tank with gold pinstriping). Used OK. deancoley@aol.com

For Sale, 1978 390 Auto, Good overall condition, No drive ( Gearbox Fault )??. Make me an offer!! Ant10ny @ aol.com Frame no ML30356, Engine no 2077 0141( husky 390 auto ), situated in Goxhill, North Lincolnshire, England. Owner, Anthony Webster, Phone (01469) 532113, Price, Offers around ££600

Wanted in San Diego - Husky in very clean condition for under \$1800. Need a good play bike after being off the dirt for 20 years. glapple@home.com

4 Husky's and 1/2 forsale call 713-778-1478

1979 Husky 390WR. New seat, brake backing plate, chain & tires. Black CR tank. Looks & runs great. \$1000 or best offer. Pete (NY) 315-433-4790 or 315-433-0039.

NOS piston kit for 250cc husqvarna . later model has half moon cutout. pt#1616357.02 \$110. and shipping NOS piston kit for husky 250cc, later with half moon cutout, pt#1616357.03 \$110., and shipping(69.94mm) NOS husky piston kit for 175cc WR or XC pt#1611266.02 first over

(64.94mm) \$110. ,plus shipping! e-mail  
hdshovel@peoplepc.com, or wideglide80@bikerider.com  
OR call (856)785-1107

For Sale: 1975 Husky 360, GP, CR, Heikki Mikkola. engine  
2045-0522, correct ML frame.Preston Petty fenders, new tire,  
excellent running condition, extremely fast, extra parts, ready to  
race or fast trail bike. \$1,250.00 or trade, I collect old Indians and  
H-D ph 814-942-1218 E-mail: Bakcycle@aol.com

Wanted: new stator for 1995 Husky 610 WXE. Please e-mail at  
deblaw223@uswest.net or phone 253-845-8895 and ask for  
Dave.

WANTED: For a 1972 250 cr, Set of trelleborg tires, set of alloy  
fenders, Metal air filter cover, Correct "Hand Grenade" silencer,  
correct seat, If anyone knows where I can get a "Visor VU" visor  
email me. Also wanted a 1966 250 cr, wanted the "on any Sunday  
bike" A 1970 MH husqvarna 400 cross in mostly original shape.  
Email, Tayman789@aol.com

1980 husqvarna cr125, excellent condition, fox air shocks, new  
aluminum swingarm, fresh tires, renthal bars, beautiful. also 1979  
125cr, easy restoration, or excellent parts bike. extra parts, forks,  
shocks (ohlins), brake backing plates, piston kit, etc. \$2500.00 for  
everything. call (914)941-6481 or e-mail to motosource@hot  
mail.com

Wanted for 1983 Husqvarna 240-250 16 11 831-02 Cylinder  
Liner or 16 11 831-04 Cylinder Liner 16 11 210-01 Piston Kit or  
16 11 210-05 Piston Kit Telephone number 011 1324 717467 - e  
mail address [gowanlea@amserv.net](mailto:gowanlea@amserv.net)

1979 CR 390 for sale in running condition and a early 80's 420  
ran last year but needs a kick start gear. Both need brakes and the  
390 has a new (99) top end. If your interested please contact:  
Troy @ 330-608-1110

1982 420 that I dont ride any more[ new wife and baby] the thing  
is in great shap and I got lots of spares and manuals. I rode and  
maintained this machine for 10 years. I bought it for \$400 in 1990  
and a running parts bike for \$500 in 96 or 97. I got spare  
magneto, engine , etc. I have lots of \$\$\$\$ in it all and looking to  
sale out. Clay 706-820-0186

I thought you may want to pass this on - . Yesterday, I was  
hanging up in the ceiling at MOM's (Motorcycles of Manchester  
located in Manchester, NH) a 360 Automatic in very good  
condition. The guy I talked to wants \$800 for it and believes it  
runs fine. A woman brought it in a few years ago and it was still  
running ok. I believe she used it for light trail riding. They are  
going to take it down and put something else up in its place. The  
tank was green and looked in very good condition along with the  
seat, fenders, motor, etc.

Hi Craig, It's been quite a while since I have talked to you. I know  
that you collect older Husky's and have parts for the older bikes,  
but I just wanted to pass on some information to you and other  
husky owners. The SEM ignition in my 87 510 te went out on me

last summer, I called all the dealers, ignition rebuilding shops,  
salvage yards, and any other place I could think of to find an  
ignition for this bike, with no luck. The problem is that the ignition  
for this bike was special and only used in the 87 model year. I  
found a supply of new SEM ignitions for this bike and will pass on  
the information to any husky owner that needs an ignition for his  
87 510te. my e-mail address is: [www.waxie@flash.net](mailto:www.waxie@flash.net). Thanks  
Craig. Sincerely, Tom Simonson

Wanted:1978-79 Husky CR or WR 250 in excellent condition.  
Contact Chuck Beers in Ohio at 937-222-4683 or Email at  
[cbeers111@aol.com](mailto:cbeers111@aol.com) or [cbeers@advertools.net](mailto:cbeers@advertools.net)

looking for a stator or whole magneto system for a1987 430  
husqvarna 2 stroke water cooled engine. email address is  
[tsalts@bellatlantic.net](mailto:tsalts@bellatlantic.net) or phone # 215-257-5741, todd

1988 WR430 \*FOR SALE\* - VIN# ZHUWR4301JV000032,  
Engine# 22020180, asking \$1500.00 or make an offer. Lansdale,  
PA. Near Phila., 215-361-7271, JOHN, e-mail,  
[jmackeyhandyman@aol.com](mailto:jmackeyhandyman@aol.com), not ridden since many new parts  
installed. needs kicker gear bearing replaced. did run great, and  
will run if pop started. Has title and owners manual.

Wanted : air cooled twin-shock frame for 4 stroke Husky any  
condition . send your offer to [cvr@busmail.net](mailto:cvr@busmail.net)

84 husky 400wr---- very good cond. , rebuilt motor top and  
bottom---cosmetically exc.---\$750 please call 406-777-5161 or  
email [brendanf@montana.com](mailto:brendanf@montana.com)

2 husky's for sale1973 husky cr 250 completely rebuilt with less  
than 2 hours on it1971 husky wr 450 also completely rebuilt 10  
hours ago.both run great, but have been sitting in my garage for a  
year.so it's time for them to go.I would like to get \$ 1250 each obo.  
Rodger Steyn from Carson City Nevada. phone # is 775-883-6883  
anytime

a 73 Husky 450. Frame #Mk02989 Engine #20310525. Have all  
parts, Engine out of bike, but it ran good before disassembling it.  
It needs rings and points. Contact Scott @[ARSin9Jin@aol.com](mailto:ARSin9Jin@aol.com) or  
(313)359-9008

1984 250WR, It as a new clutch and rings, runs very strong, starts  
usually first kick. An amazing bike for the year.I'm in northern  
Ohio.Asking price \$900 Email me at [gastrac@stratos.net](mailto:gastrac@stratos.net) name is  
Mike

For Sale: 1970 Husqvarna 400 Cross, MH4270. All original in  
excellent unrestored condition. Tank has the original bright red  
color. No dents, scratches and no paint fade. Seat is original with  
no color fade and no rips. Engine is still strong with standard bore.  
Have spare tank, 2 gasket sets, 2 sets points and fork seals.  
Located in San Francisco/California. \$3000. Cy, pager: 415/978-  
7997, ([cyee88@yahoo.com](mailto:cyee88@yahoo.com)).

88 WR430 with title for sale. Runs strong but kicker gear bearing  
needs replacing. Many new parts.Invested over 2 grand and hasn't  
been ridden. Make offer. 20 miles W. of Philadelphia Pa. John  
215-361-7271

Wanted Husky Mag 250 - Husky club member Gary Johnson is looking for a race ready 250 mag.. Please e-mail Steve Kerr - skerr@bright.net

WANTED: '79 390 (or equivalent) Husky for parts. Monterey, CA area. Alan (831) 642-9525-or alan@redshift.com

wanted 78 390 or rear upper fender, air filter, seat, tank. contact cameron at 310-541-9060 in palos verdes california. or email camb@web.com

Wanted Looking for a flywheel puller that will work on a 1976 WR 250, this bike has the Fems point system in it. You can contact me through my e-mail address given. Thanks JRJAM79@aol.com Jon Wynn

WANTED: Fuel tank for '75 Husky GP/CR360 in great to new condition. Will pay top dollar for right one. Also, Pro-fab or similar billet triple clamps with different offset for better turning. Call Terry at (940)380-1496 or e-mail at TerryTouchdown@aol.com.

Hi, I am looking for a left side engine crankcase half for my 1982 250 WR and bushings for the rear shocks (upper and lower) if you have any info on these parts please let me know. Ralph Gannarelli RGannarell@aol.com 602-920-1030

Looking to buy a 81 or 82 250 or 430 CR or XC. Also looking for a 78-80 125CR. Looking for resto. projects. FWellck @cs.com So. Cal.

Looking to sell 85 510 TE not ridden for a while VERY LOW MILES!!! Has mikuni carb. & M.S. skidplate. Asking \$750 or trade for 78-82 250 CR, OR, XC Fwellck@cs.com

1981 Husky 250 XC forks complete, nice condition no rust, \$100, plus shipping or trade for a good pair of 15 in shocks for my 250 WR. 1971 400cc 4 speed husky frame, and swingarm, \$60. plus shipping. 1976 husky front wheel, from wr good condition \$35., no brakes, just wheel and hub. 1981 husky 250XC, front wheel complete, with brakes backing plate and axle, \$65. and shipping. 1981 husky 250 XC frame and swingarm \$80. plus shipping. mahle NOS piston kits includes ring wristpin and circlips, 1982 to 1984 husky 500cc Pt# 16-11-194-01 standard 85.92 mm \$130. and a little to ship. also 1982 to 1984 husky 500cc Pt#16-11-194-03 third over piston kit 86.92mm \$139 and a little to ship! Thanks!! from bill in s. jersey! "BILL" <HDSHOVEL@PEOPLEPC.COM>

For sale 1976 Husqvarna 360 WR with 390 top end, runs good. Mostly original except for fenders \$600.00 Phx AZ Contact Joe at (602) 843-9691 or email theclassicone@usa.net

Have a complete original 250 cross for sale. The frame is mi 48\*\* and the motor is 254\*\*\*. It is in really great original shape, has compression, And spark but the carb needs rebuilding ( the float sticks And continually floods when the gas is left on ) I would like to start with an asking price of 500 , But am open to offers because I need to sell this

Fairly soon. Any help you can give me finding a buyer Would be greatly appreciated. Thomas adkins 340 w. bethesda rd. Burleson, texas 76028-1631, Tom Adkins <tom.adkins@texstars.com>

i need a rearwheel assembly, and a side cover with water pump for an 1987 husky 430 if anyone has these e-mail me at bj797@webtv.net

Need lower end and throttle assembly for '73 125CR Husky, will buy entire engine if tranny/casing is good. Top end not important (can be fried) Will Gorges New Bern, NC (252)636-3039 or email rebel@civilwarantiques.com Have PARTS for 250 WR/CR series to trade if thats what it takes!

Wanted 1973-74 Husky 125CR in race shape. Not looking for museum piece, just a solid AHRMA Classic 125 legal bike. Prefer bike in the northeast. Terry McDonnell 607.776.3204 before 10pm EDT, e-mail tpmcd@hotmail.com.

WANTED: silencer for and 81' 430 XC. email- caruso@mind.net or 541-899-4414

Wanted parts for 1993 360 wxe or info about this bike and its pros and cons. Epirtle@riteway.com eric 314-351-2989

WANTED HUSQVARNA 510 four stroke air cooled, any year, any condition, or just motor or just top end also any manuals for the 510 series air cooled and water cooled. shop@computerassistance.uk.com

1980 250CR -- fully restored and ridden only three times. Husky manual and training booklet and original 1980 promotional posters come with the bike. \$1,500. Call Chris in New Jersey at 609-714-6869 or e-mail at collom@snip.net.

Needed new engagement gears for 78 390 auto, also ( new black/chrome Tank )mike dennis 1-949-837-0045 mikedenn@pacbell.net

N.O.S. 125 Husqvarna parts, for sale Front brake hub #15-16-089-01, New piston kit #16-11-435-01 std. for 175 GP, 5 fibre clutch plates #16-11-965-01. Sell or trade for CZ parts. E-Mail above or call Chris 352-383-0946 in Florida - MXWFO@webtv.net (CHRIS MCILWAIN)

'79 cr390 new motor, fork seals, ect. runs & looks great \$1000 or best offer .

'78 cr390 new motor, new rear shocks, runs & looks great \$1000 or best offer .

'77 wr360 good compression needs little tlc \$600 or best offer Thank's Bill Porciello <pporciello@snet.net>

1987 wr430 runs great, excellent for parts or refurb. Fresh top and bottom end. 1991 wxc 350 excellent parts bike opportunity, needs L/E work. Contact Staplejo1@aol.com , John @ 810 772-7719

For Sale: 1975 Husky 360, GP, CR, Heikki Mikkola. engine 2045-0522, correct ML frame. Preston Petty fenders, new tire, excellent running condition, extremely fast, extra parts, ready to race or fast trail bike. \$1,250 or trade, I collect old



wanted. late model front end complete, from 93 or later, froks tripple clamps wheel, or partial front end, must be late model. Capt John, 781-641-3474 or [gonfishn@tiac.net](mailto:gonfishn@tiac.net)

Seat from a 1979 390 OR for sale, except for one 3" cut it's in almost new condition. Asking \$50. I will pay shipping in the US, please call Dave at 912-956-0294 or e-mail [dnr91@yahoo.com](mailto:dnr91@yahoo.com)

I am about to manufacture some clutch shoes ,( first gear) . does any one know if aluminum bronze ( ampc bronze) would be a suitable material? im also about to make the clutch hub as well, unless someone has one to sell. 1978 390amx. i live in the chestnut mountain area (Road Atlanta) OF Gainesville Georgia 770-967-8142. [mpoole9783@aol.com](mailto:mpoole9783@aol.com)

WANTED: piston kit for 76 husky 360. (623) 848-6118, [arizmxmike@aol.com](mailto:arizmxmike@aol.com)

FOR SALE: aluminum triple clamps (thick one's) for your husky, good shape, \$80.00 (623) 848-6118 [arizmxmike@aol.com](mailto:arizmxmike@aol.com)

For Sale: 1983 XC 500 fr#X011267 eng#20943215 Needs cylinder, rings, air filter and gaskets to reassemble top end. Otherwise complete (good 2nd over piston included). Good condition for a 17 year old dirt bike. Includes parts bike. \$350/OBO. If you have a cylinder, I might be interested. I'm also looking for NOS Puch 175 MX/enduro parts. Los Angeles CA area. E-mail [Matthew\\_Winiarski@ahm.honda.com](mailto:Matthew_Winiarski@ahm.honda.com) Ph# (310) 320-3719 (leave message)

1982 Wr430, and a 1979 Wr390. All I need is air filters and these bikes are back on the trail. They have been garaged for twelve years, and are like new. I am going to sell them. I have a trailer also. I will sell the two bikes and the trailer for \$2000. I live in Cheraw South Carolina. Looking at these bikes is like looking into a time capsule. Rusty Price

Want to buy motor for automatic. Must be complete. (360) 574-5000 x263. [pathfind@e-z.net](mailto:pathfind@e-z.net).

'82 Husky for sale. 430. Frame stamp cm11459. Desert tank. Runs great. Been in storage for a few years but licensing is up to date. \$1000/Best offer. Email [DougLynch2@aol.com](mailto:DougLynch2@aol.com)

For Sale: 87 TE510 enduro. Excellent condition, runs very strong with new top end. Have another complete 510 for parts and engine manuals. \$1900 for all. Lisbon, Ohio. (330) 424-7463

for sale 1985 husky cr 250. needs minor engine work, plastic is good. make me a offer, open to trades. call tim at (207) 929-8287 or e-mail at [imok@cybertours.com](mailto:imok@cybertours.com)

86 husky cr 250 frame #842251951hxp25088/engine #21350257 looking to sell my bike fresh engine top and bottom, rear shock rebuilt with new spring. new front & rear sprockets will consider trade canton, ohio \$1300 call (330)495-5172 mike

Wanted: 1973 Husqvarna 125 SC motoplat coil, Amal carb, and rear wheel. [deancolley@aol.com](mailto:deancolley@aol.com). Located in So Cal.

I have an old husky that i've had for about 20 years. it's a 76 wr360. I would like to sell it. Right now it's all in a bucket,

but i have collected some of the parts to do a rebuild. I have a new rod and i think the overbore piston. I hate to just throw this away. If i could get 100 dollars for it i be glad. I'm in the sacramento, cal area. Thanks Dan Bergeron "Dan" <[kzdanno@lanset.com](mailto:kzdanno@lanset.com)>

I need the rubber piece that goes between the airbox and the Mikuni carb on a '76 360 WR. Are there any out there? Vintage Husky doesn't have it. I have a NOS cable for a '76 360 Auto. The cable to engage the tranny. Anybody need one. I have some other odd parts as well. Thanks, Ron Connors [roncon@simplyweb.net](mailto:roncon@simplyweb.net)

WANTED: HUSKY 250XC -1982 Gas tank in good condition without dents, do you have any, PLEASE contact me Anders Sinjarv at [jarven@home.com](mailto:jarven@home.com) or 602-971 1204.

1973 ? husky ser no. sk 00462 motor no. 2026 0146 runs and rides complete bike \$500. two sets fork legs \$50. set of wheels 18&21, gas tank \$35. bottom end ser no 2019-1678 and cyl and head 150. located in mich e mail TuttiLaine @ aol.com 05-01-00 or 810 329 6844

I have many parts early to mid 80s big bore two stroke (390 430 500 ect.) to sell or trade for parts my friends and I are in need of. Yoy can reach me at (503)788-0823 ask for Ron, or better @ [JAVA-BRO@msn.com](mailto:JAVA-BRO@msn.com) .PS. I 'me looking for a mag. for a 1983 XC 500 , thanks Ron huret Portland OR.

For Sale, 1984 Husqvarna 250CR. Very good condition, runs great. Has new Motoplat XC ignition. Too many other new parts to list. Asking \$900.00. Pics available. (618)937-3506 [sailer@hcis.net](mailto:sailer@hcis.net) .Located in Southern Illinois. Can ship motor freight.

I need a front hub or complete front wheel assembly for a 1986 WR 400 Please call 417 833 1711 or E-mail me at [thatfield@pcnetinc.com](mailto:thatfield@pcnetinc.com)

For Sale - Husky project bikes, very complete, I just don't have time to handle all these projects - 1968 250T Husky Commando , 90% complete ; 1968 Husky 250 cross and a 1971 Husky 360 enduro - please call Bob White in Arizona at 520-428-5721 after 6pm AZ time.

For Sale/Trade: 74 CR "Mag" 250 (MK18129,2033-1943), This bike is beyond my restoration skills, but would make a great parts bike for someone restoring the same model/year bike. Lets work a trade for a mid to late seventies 250cc+ Husky in more restorable condition. For east coasters (I am in SC) I will travel up to 6 hrs to meet and trade bikes. Call or email me at 864-227-8271 (after 5pm ask for Tim) or [tabrookhaven@greenwood.net](mailto:tabrookhaven@greenwood.net)

For sale: for 72 250 husky mx. Front and rear wheels very nice shape sholderless arkont style rear wheel and front complete assemblys with sprocket brake assemblys which is in excellent shape axils and all \$50+shipping each ,also tank good shape but painted\$50,and othe parts email me for pictures and better list of items. Email me at [kt250@cillnet.com](mailto:kt250@cillnet.com)

Indians and H-D ph 814-942-1218 E-mail: Bakcycle@aol.com

I am tired of pushing or buying trail gas off so called buddies! I am looking for larger enduro tank for 1978 cr390, plastic or metal ok. polcat1998@aol.com

Wanted: plastics for 84 mod WR240 front and side covers. Contact darrell on 61 7 49971773 or darrell\_maybury@hotmail.com

Wanted: A 360 C Sportsman any year, that runs. and a 1966 250 cr that has most or all parts running or not. Email Tayman789@aol.com or call at (716) 633-7829 ask for taylor

87 510 Four Stroke with a 90 motor, upside down WP forks, supertrapp spark arrester, two into one pipe , \$1400 , , Jeff , Oxford, ms. , 662-234-5608 , e-mail- omclc@dixie-net.com

I am looking for a Piston kit for my 1983 Husqvarna TE510 air cooled four stroke twin shock, I would be grateful if you could check the following part numbers for availability or if you know of anybody who would have one, 16 15 065-01 Piston kit 90mm , 16 15 065-02 Piston kit 90.5mm , 16 15 070-01 Piston kit 91.5mm, 16 15 070-02 Piston kit 92mm , 16 15 367-01 Piston kit 91.5mm, Willie Hutchison. "<gowanlea@amservice.net> in Scotland

For Sale: 74 Husqvarna 125 SC. Very nice, very fast. AHRMA legal. Only difference between this SC and a 125 CR(Husky) is 2nd and 3rd gears are a little wider, not as wide as a WR. I rode both and cannot tell the difference. This one runs real strong. It's the one in the foreground, the other one is sold. Restored several years ago, tank has been painted and the fenders are new, Akront alloy rims. Tank does have a small dent in the side. Ready to race. Current green sticker. Make me an offer.

For Sale: 74 Husqvarna 125 SC. Basket case. Missing pipe and air cleaner. Extra motor.

E-mail [VintagJerry@home.com](mailto:VintagJerry@home.com)

**DON'T MISS OUT SUBSCRIBE**  
**No 8 OUT NOW**



Same old dirt...  
Same old bikes...  
Same old fun!

Get the leading International Classic Dirt Bike Quarterly hot off the presses! Order direct by phone, fax or email. Single issues or 12 month - 4 issue subscription.

**NOW AVAILABLE - NON-AIRMAIL SUBSCRIPTIONS \$48 - FOUR ISSUES.**

Back issues #1 thru #7 now available  
Contact Mark Thompson  
Too Due LLC, 8882 Timberchase Court,  
West Chester OH. 45069-6486  
Tel 513 942 4019 Fax 513 942 4021  
email: [markthomp@juno.com](mailto:markthomp@juno.com)  
web: [www.vmx-mag.com](http://www.vmx-mag.com)



**AIRMAIL SUBSCRIPTIONS-**  
Contact VMX direct. Four issues airmail US\$56  
Single issues US\$14 Credit Cards & Personal Checks- OK  
VMX Magazine PO Box 578 Kyneton 3444 Australia  
Tel 61 3 5422 7510 Fax 61 3 5422 7511

Also check out VMX on [www.vmxmag.com.au](http://www.vmxmag.com.au)

## HUSQVARNA MOTORCYCLE CLUB

is a newsletter club dedicated to Husqvarna and related motorcycle marques. Newsletters will be a 16 -20 page publication with 6 issued per year at a membership of \$20 for USA/Canada and \$29 for all others. To join, send check payable to Craig Comontofski and mail to : **Husqvarna Motorcycle Club, 1501 West King Street, Martinsburg, WV 25401**

Also include your phone number, e-mail address, Husky bikes you own, or are interested in. Frame# and engine #'s for bikes owned would be great! As a member you will be able to post a reasonable amount of free Husky-related advertising. We also desperately need articles about experience, tech questions, classifieds, parts leads, whatever from the general membership, including copies of old literature, and good photos of your Husky bike and you. For commercial businesses, here are the very reasonable rates for your ads: 1/8 page - \$15 per issue, 1/4 page - \$25 per issue, 1/2 page - \$45 per issue, full page - \$75 per issue We can provide artwork for your ads, if you like, for \$40-\$80 (one time charge). Also, if you are a paid advertiser, we will offer you a free, one-time article or maybe even more if there is tech or valuable product info (with photos/pictures if possible) on what you offer the Husky Hobbyists. An E-mail format is best.

Key Tag (chain) - Each Beverage Wrench is made of tuff nylon plastic with a stainless-steel insert that stands up to tough-to-open bottle caps and pop-top beverage and food cans. Includes a 1" split-ring for use as a key-tag. White with blue logo and letters. One way its will open bottle caps the other it will open aluminum pop top cans - 1ea for \$8, 2 ea for \$12 ship \$3.20 priority. Mail Craig Comontofski, 1501 W. King Street, Martinsburg, WV 25401

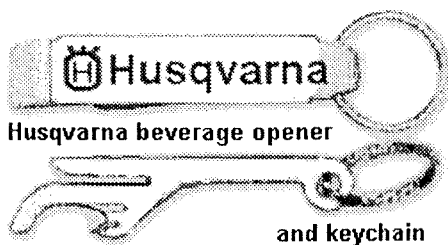

## VINTAGE HUSKY

Reproduction Parts-N.O.S. Parts  
Complete Restorations  
Race Ready Motorcycles  
Bike Rentals  
Complete Engine Rebuilding  
Painting - Gas Tanks - Frames  
Decals - Stickers  
Complete Suspension Work  
Machining Done In-House  
Welding - Fabricating  
Trelleborg Tires

Progressive Suspension Dealer  
Shocks & Fork Springs



We Do Everything  
When It Comes To Your  
Husqvarna Motorcycle

760-744-8052

155 Balboa St. D-2 San Marcos, CA 92069



# \*\*\*\*\* Rod Kits for Huskys !!!

Now Available from your Husky Club Dealers!!

Year	Model/Size	Euro-Rod #	Con-Rod BE x CTC x SE	Pin od x lngth
72-74	125	ER1610-73101	26 x 92 x 19	20 x 47
75-83	125	ER1610-38301	26 x 97 x 19	20 x 48
85-88	125	ER0610-53192	26 x 105 x 20	20 x 54.6
89-90	125	ER0578-60393	26 x 110 x 20	20 x 54.5
91-94	125	ER0590-67239	26 x 110 x 20	20 x 54.5
88-91	250	ER800L-50632	30 x 125 x 22	24 x 64
67-70	360/390/400	ER1619-90201	32 x 135 x 22	25 x 52
70-80	250-430	ER1619-82501	32 x 135 x 22	25 x 58.3
80's	510	ER 4STK-63840 EG	38 x 127 x 20	30 x 59.9
90's	350-410	ER 4STK-63840 EG	38 x 127 x 20	30 x 59.9
90's	610	ER 4STK-67825 EG	38 x 127 x 22	30 x 59.9
80's	510	ER 4STK-63840 EC	38 x 127 x 20	30 x 59.9
90's	350-410	ER 4STK-63840 EC	38 x 127 x 20	30 x 59.9
90's	610	ER 4STK-67825 EC	38 x 127 x 22	30 x 59.9

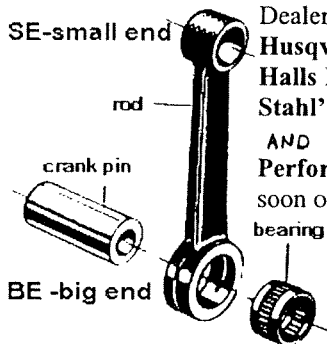

Dealers to call -

Husqvarna 4 Speed (304) 267-6471  
Halls Husky (217) 528-8356,  
Stahl's Husky (765) 284-7653

AND

Performance Vintage Prod (502) 387-3993  
soon others.

Joe Fredrickson of Euro-Rods is pleased to announce that a full supply of Husky rods are now available and more are in the works. Euro-Rods will not be retailing any rod kits, so you will need to deal thru the following Husky Club dealers. Other items - Euro Rods can supply the Husky 450 small end bearing and custom rods.





## PERFORMANCE PVP VINTAGE - PRODUCTS



Husqvarna

---

Husqvarna Specialist - Expert Restorations  
N.O.S. and Used Parts Available  
*Custom High Performance Parts and  
Modifications Available for Husqvarnas*

---

**PVP.**  
839 East Burnett Avenue  
Louisville, Kentucky 40217  
(502) 387-3993 or (502) 634-9774

---

**Bike Builder & Sponsor of Andy Hardin  
1998 - 40+ and 500 Sportsman  
AHRMA MX Champion**





## Husqvarna

**Husqvarna Banners for your Shop or Garage!**  
These banners are 2' by 6' and are constructed of an outdoor quality vinyl. The logo and lettering is silkscreened onto the vinyl, this is not stick on lettering! All four sides are hemmed and double stitched and there is a heavy grommet in each corner to allow you to bungee cord fasten this banner in place. The lettering/logo are white, the background is royal blue. There are also nylon cords sew in to allow you tie into place. **Hang one in your garage!**  
**Take one to the races and display Husqvarna!**  
Club price is \$30 plus \$3.20 to ship = \$33.20.  
(Retail is \$35) There is a limited quantity of these so don't delay - 304-267-6471 or husky@intrepid.net

GO-KARTS



## JS & S



Husqvarna

---

**YOUR MOTOCROSS HEADQUARTERS  
SALES PARTS & SERVICE**

U-HAUL

715-342-3888  
888-777-4FUN  
FAX: 715-342-3880

ATVs  
SNOWMOBILES

3505 CHURCH ST.  
STEVENS POINT, WI 54481

---

LAWN & GARDEN

BICYCLE RENTAL

TRAILERS

**Thank You to  
JS&S Power  
for a great  
poster, hat,  
and mug!**

# Husqvarna 1982 all models - Parts List Page 76

Luftfilterbox  
Air filter box

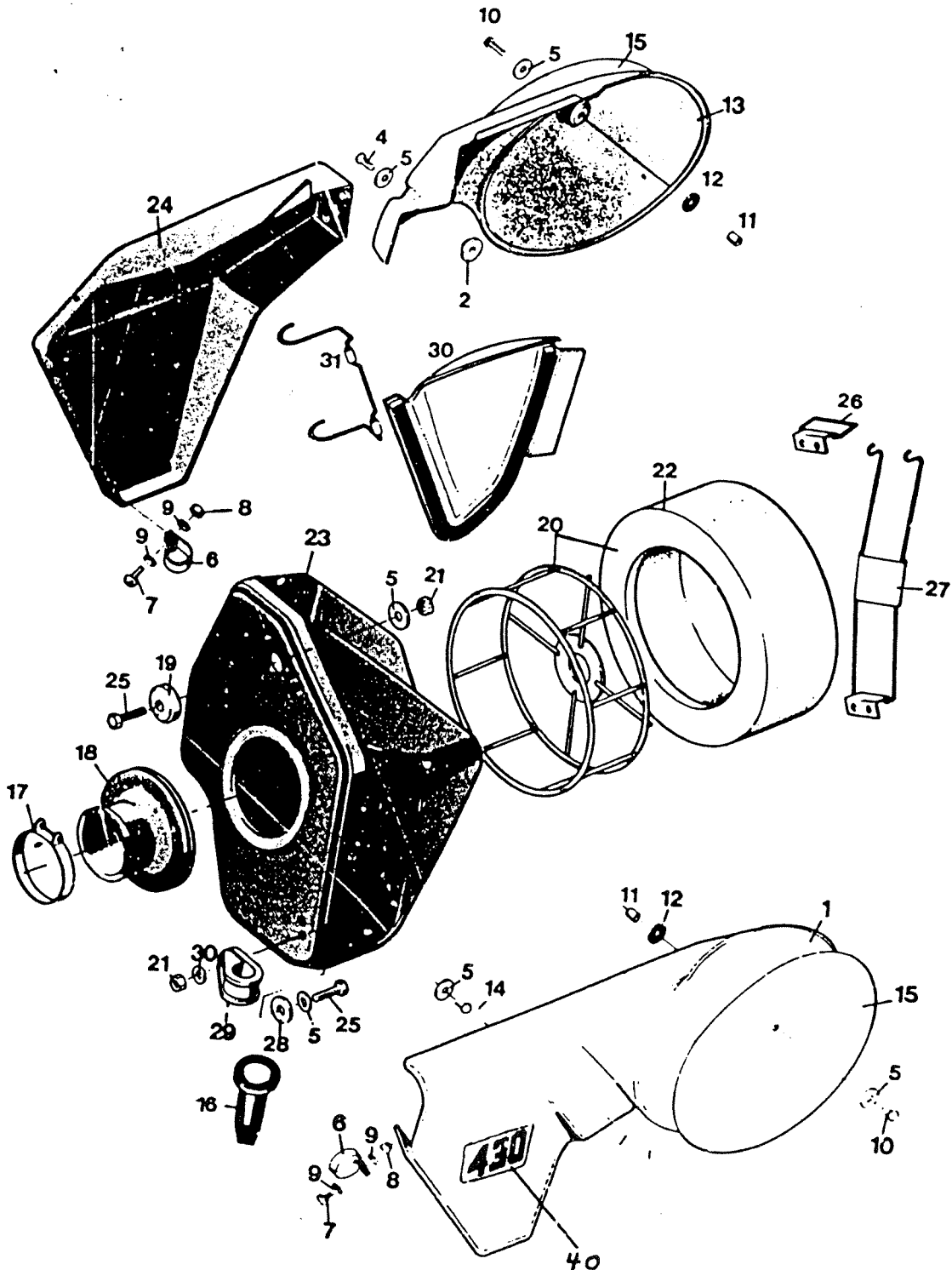

# Husqvarna 1982 all models - Parts List Page 77

Fig	Part Number Detailnummer	Quantity/Antal												Description Benämning	
		125			250			430							
		CR	WR	XC	CR	WR	XC	CR	WR	XC					
N 1	15 19 694-01				1		1								Sidopanel, vänster Side cover left
N	15 19 693-01	1	1	/			1		1	1	1				Sidopanel, vänster Side cover left
N 2	15 19 696-01	1	1	/	1	1	1	1	1	1	1				Distans Distance
4	72 52 368-53	1	1	/	1	1	1	1	1	1	1				Skruv M6x16 Screw
5	15 13 709-01	5	5	5	5	5	5	5	5	5	5				Bricka 6,5x22 Washer
6	15 14 201-01	4	4	4	4	4	4	4	4	4	4				Klamma Clamp
7	72 31 291-01	4	4	4	4	4	4	4	4	4	4				Skruv M4x12 Screw
8	73 22 112-01	4	4	4	4	4	4	4	4	4	4				Mutter M4 Nut
9	15 13 728-01	8	8	8	8	8	8	8	8	8	8				Bricka 4,3x12 Washer
10	72 52 372-53	2	2	2	2	2	2	2	2	2	2				Skruv M6x25 Screw
N 11	15 19 704-01	2	2	2	2	2	2	2	2	2	2				Distans Spacer
N 12	15 19 705-01	2	2	2	2	2	2	2	2	2	2				Gummiömföring Rubber spacer
N 13	15 19 695-01	1	1	/	1	1	1	1	1	1	1				Sidopanel, höger Side cover right
14	72 52 364-53	1	1	/	1	1	1	1	1	1	1				Skruv M6 - 10 Screw
15	15 19 573-01 15 19 573-02 15 19 573-03	2	2	2	2	2	2	2	2	2	2				Nummer oval, vitt Nummer oval, grön Nummer oval, gul
16	15 14 324-01	1	1	/	1	1	1	1	1	1	1				Dräneringsventil Drain valve
17	16 13 539-01	1	1	/	1	1	1	1	1	1	1				Klamma Clamp
18	15 14 984-01				1	1	1	1	1	1	1				Anslutning Connection
	15 14 301-01		1												Anslutning Connection
N	15 14 465-01	1		/											Anslutning Connection
19	15 19 342-01	1	1	/	1	1	1	1	1	1	1				Gummbussning Rubber bushing
20	15 14 981-01	1	1	/	1	1	1	1	1	1	1				Korg Basket- FILTER COMPL
21	73 22 116-01	2	2	2	2	2	2	2	2	2	2				Mutar M8 Nut
22	15 14 983-01	1	1	/	1	1	1	1	1	1	1				Luftfilter
23	15 14 979-01	1	1	/	1	1	1	1	1	1	1				Luftfilterburk Air filter box
24	15 14 991-01	1	1	/	1	1	1	1	1	1	1				Lock Cover
25	72 52 371-51	2	2	2	2	2	2	2	2	2	2				Skruv M6x22 Screw
26	15 14 906-01	1	1	/	1	1	1	1	1	1	1				Länk Link
27	15 14 985-01	1	1	/	1	1	1	1	1	1	1				Bygel Filter holder
28	15 18121-01	1	1	/	1	1	1	1	1	1	1				Gummirbricka Rubber washer
29	15 18 137-01	1	1	/	1	1	1	1	1	1	1				Fäste Attachment
30	15 14 412-01		1			1	1		1	1					Tätningsskiva Splash guard
31	15 14 413-01		1			1	1		1	1					Hållare Holder
40	15 19 712-07							2							430 STICKER-CR
	15 19 712-08								2						430 STICKER-WR
	15 19 712-09									2					430 STICKER-XC
	15 19 712-09				2										250 STICKER-CR
	15 19 712-05					2									250 STICKER-WR
	15 19 712-01	2													125 STICKER-CR
	15 19 712-02		2												125 STICKER-WR
	15 19 712-03			2											125 STICKER-XC
	15 19 712-06						2								250 STICKER-XC

# The New "WRX" Not a WR, Not an XC Definitely a Husqvarna

Our new WRX is a blending of the two most successful off-road motorcycles in history, the WR-Enduro and XC-Cross Country. Each has won championships around the world in its respective sport.

But many of you have asked us for an enduro machine with single-shock technology, and a longer wheelbase and suspension that can also be used for hare scrambles or desert use. Your wish is our command! Available now, in both 400 and 250cc versions, the new WRX has all the exciting features that make a Husqvarna something very special:



- Enduro lighting system

- High-output liquid cooled engine with magnesium case

- Fully adjustable single shock rear-suspension with Ohlins Shocks

- Premium quality European tires

- the Husqvarna warranty

- Handcrafted quality

Remember, the WRX does not *replace* the WR or XC. It is a special machine with all-around competitive capabilities, and may well be the most fun you've ever had on two wheels.

Check out the WRX and all the new '85 Husqvarnas at your dealer now. The winner's circle awaits.

- Ultra-durable chrome-moly lightweight frame with aluminum swing arm

- U.S. Forest Service approved, low-maintenance spark arrestor

## Husqvarna

THE FINAL STEP UP

Husqvarna Motorcycle Co. • 4925 Mercury Street  
• San Diego, CA 92111

# Öhlins Husqvarna Single Shock

Part 3 of 3

I am trying to include here a portion of the 31 page picture overhaul/parts list manual. The past 2 newsletters (17 and 18) have the full text overhaul instructions issued in 1986. These had no pictures to accompany them, but I did add some exploded views and text to help clarify the text. Here is a portion of the Parts manual. Happy Huskys.

1-A Husqvarna 1988

4-T MX  
4-TE  
430 AE

HA 5140  
HAW 5130  
HAW 4300

Fig. No.	Part number Designation	Quantity/Anzahl		Description Benämning	Remark Anmär.
		4-T MX	4-TE 430 AE		
1	503-02	1	1	Bump rubber Stoppgummi	
2	505-02	1	1	Cap Skyddlock	
3	575-01	1	1	Circip Låring	
4	502-01	1	1	Washer Bricka	
5	527-02	1	1	Seal Tätning	
6	644-01	1	1	Washer Bricka	
7	527-01	1	1	X-ring X-ring	
8	558-01	1	1	Bushing Bussning	
9	578-01	1	1	O-ring O-ring	
11	529-01	1	1	Seal head, easy 78mm gånghuvud, kop	
13	816-01	1	1	Washer Bricka	
14	815-01	1	1	Rubber stop Gummistopp	
15	559-02	1	1	Circip Låring	
16	638-01	1	1	O-ring O-ring	
17	813-02	1	1	Spacer Distans	
19	814-04	1	1	Spacer Distans	
20	568-25	1	1	Adjustment rod Justeringsstång	
21	612-04	1	1	Shaft Kohvstång	
22	540-01	1	1	Supporting Stödjning	
23	577-01	1	1	O-ring O-ring	
24	555-02	1	1	Adjustment valve Justeringsventil	
25	521-02	1	1	Piston holder Kohvållare	
26	625-02	1	1	Jet Munstycke	
28	619-01	1	1	Stop washer Stoppsbricka	
29	-	-	-	Shims Shimor	Sep. list Sep. lista
30	541-01	1	1	Teflon band Teflon band	
31	514-10	1	1	Piston Kohv	
32	578-01	2	2	Washer Bricka	
33	535-01	1	1	Lock nut Låsmutter	

PARTS MANUAL SINGLE SHOCK

Piston rod Kohvstång

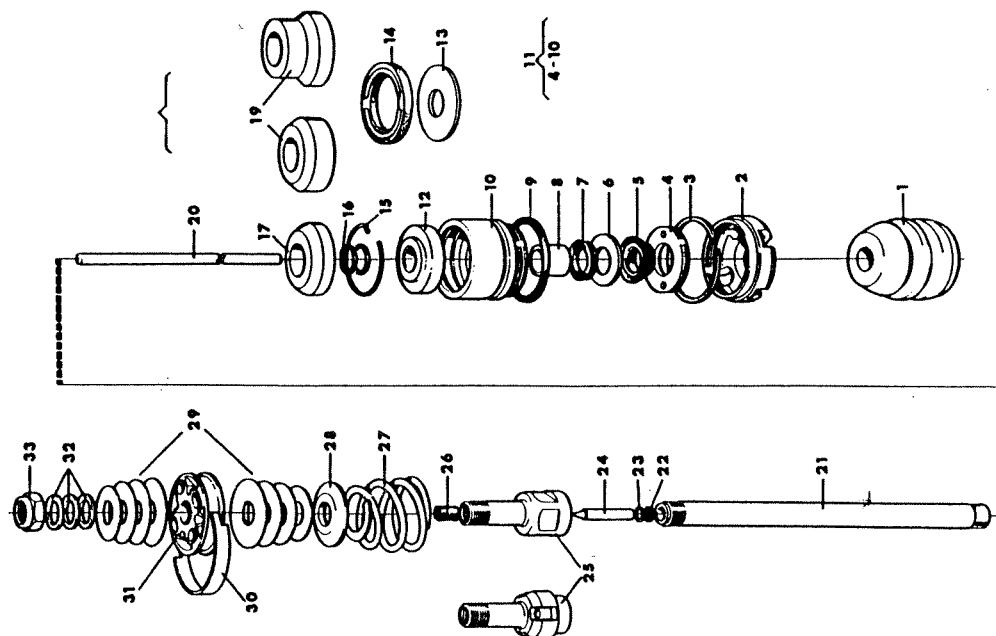

Öhlins Racing Box 772, Kramavägen 3, S-194 27 Upplands Väsby, Sweden  
Telephone 0740-880 30, International +46 740 880 30



# Öhlins Husqvarna Single Shock

1-C

Husqvarna 1988  
 125 WR  
 250 WR  
 500 WR  
 HAW 1258  
 HAW 2508  
 HAW 4008

Fig. No.	Part number Designation	Quantity/Ansät			Description Benämning	Remark Anm.
		125	250	500		
1	563-02	1	1	1	Bumpubber Stoppgumm	
2	565-01	1	1	1	Cap Skyddslock	
3	576-01	1	1	1	Circlo Läsnig	
4	562-01	1	1	1	Washer Bricka	
5	527-02	1	1	1	Seal Tättning	
6	644-01	1	1	1	Washer Bricka	
7	827-01	1	1	1	X-ring X-ring	
8	566-01	1	1	1	Bushing Bussning	
9	576-01	1	1	1	O-ring O-ring	
11	829-01	1	1	1	Seal head, easy Tättningshuvud, lät	
14	815-01	1	1	1	Washer Bricka	
15	569-02	1	1	1	Rubber stop Gumm stopp	
16	638-01	1	1	1	Circlo Läsnig	
17	813-01	1	1	1	O-ring O-ring	
20	566-25	1	1	1	Spacer Distans	
21	612-04	1	1	1	Adjustment rod Justeringsstång	
22	541-01	1	1	1	Shaft Ax	
23	577-01	1	1	1	Supporting Stödjing	
24	565-02	1	1	1	O-ring O-ring	
25	521-02	1	1	1	Adjustment valve Justeringsventil	
26	625-02	1	1	1	Piston holder Kolvållare	
28	519-01	1	1	1	Jet Munstycke	
29	-	-	-	-	Stopwasher Stoppbricka	
30	541-01	1	1	1	Shims Shimor	
31	514-10	1	1	1	Teflon band Teflon band	
32	578-01	2	2	2	Piston Kolv	
33	538-01	1	1	1	Washer Bricka	
		1	1	1	Lock nut Låsmutter	
						Sep. list Sep. lista

1-B Husqvarna 1988

125 CR  
 250 CR  
 500 CR  
 HA 1256  
 HA 2506  
 HA 5006

Fig. No.	Part number Designation	Quantity/Ansät			Description Benämning	Remark Anm.
		125	250	500		
1	563-02	1	1	1	Bumpubber Stoppgumm	
2	565-01	1	1	1	Cap Skyddslock	
3	576-01	1	1	1	Circlo Läsnig	
4	562-01	1	1	1	Washer Bricka	
5	527-02	1	1	1	Seal Tättning	
6	644-01	1	1	1	Washer Bricka	
7	827-01	1	1	1	X-ring X-ring	
8	566-01	1	1	1	Bushing Bussning	
9	576-01	1	1	1	O-ring O-ring	
11	829-01	1	1	1	Seal head, easy Tättningshuvud, lät	
13	816-01	1	1	1	Washer Bricka	
14	815-01	1	1	1	Rubber stop Gumm stopp	
16	569-02	1	1	1	Circlo Läsnig	
19	811-02	1	1	1	Spacer Distans	
20	566-25	1	1	1	Adjustment rod Justeringsstång	
21	612-04	1	1	1	Shaft Ax	
22	540-01	1	1	1	Supporting Stödjing	
23	577-01	1	1	1	O-ring O-ring	
24	565-02	1	1	1	Adjustment valve Justeringsventil	
25	521-04	1	1	1	Piston holder Kolvållare	
28	625-02	1	1	1	Jet Munstycke	
29	-	-	-	-	Stopwasher Stoppbricka	
30	541-01	1	1	1	Shims Shimor	
31	514-10	1	1	1	Teflon band Teflon band	
32	578-01	3	3	3	Piston Kolv	
33	538-01	1	1	1	Washer Bricka	
		1	1	1	Lock nut Låsmutter	
						Sep. list Sep. lista



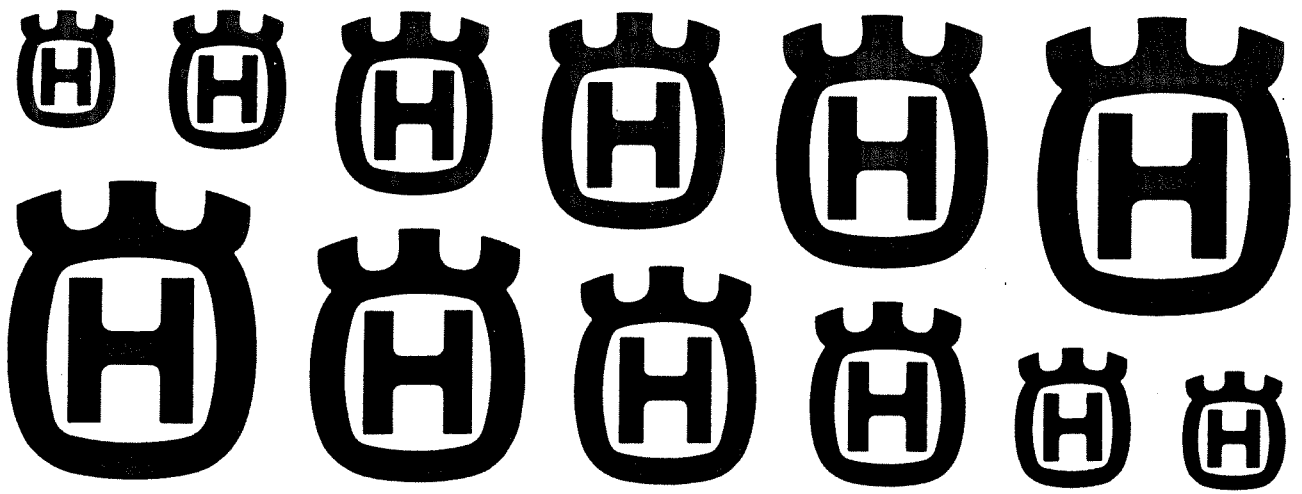

**Husqvarna**

**Husqvarna**

**Husqvarna**

**Husqvarna**

Husqvarna

Husqvarna

**Husqvarna**

**Husqvarna**

**Husqvarna**

**Husqvarna**

Husqvarna

Husqvarna

**Husqvarna**

**Husqvarna**

**Husqvarna**

**Husqvarna**

**Husqvarna**

**Husqvarna**

**Husqvarna**

# Husqvarna 73-75 250/360 RT - Wiring Diagram

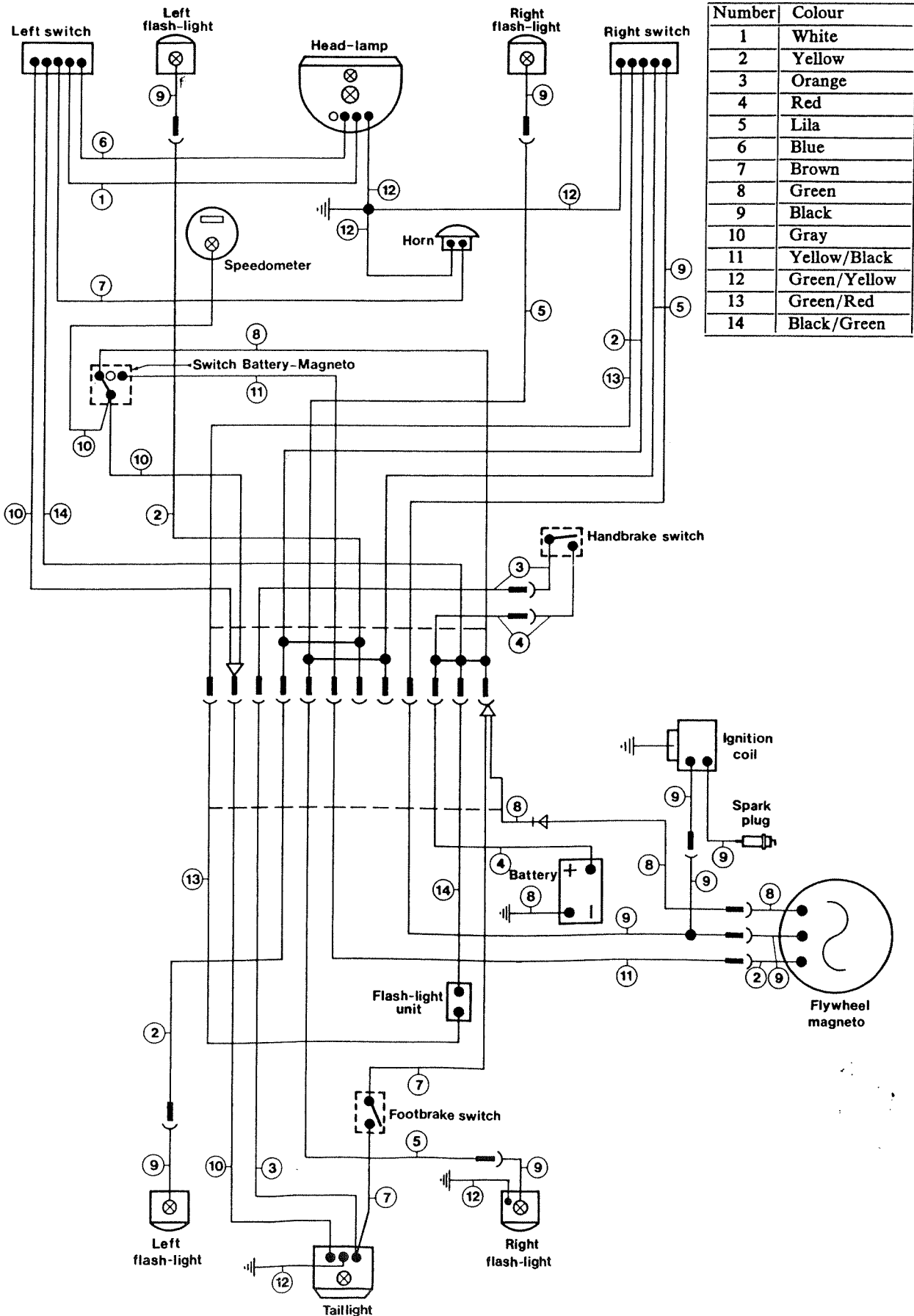

Number	Colour
1	White
2	Yellow
3	Orange
4	Red
5	Lila
6	Blue
7	Brown
8	Green
9	Black
10	Gray
11	Yellow/Black
12	Green/Yellow
13	Green/Red
14	Black/Green

# ALUMINUM SWINGARMS IN 6061 T6 ALLOY

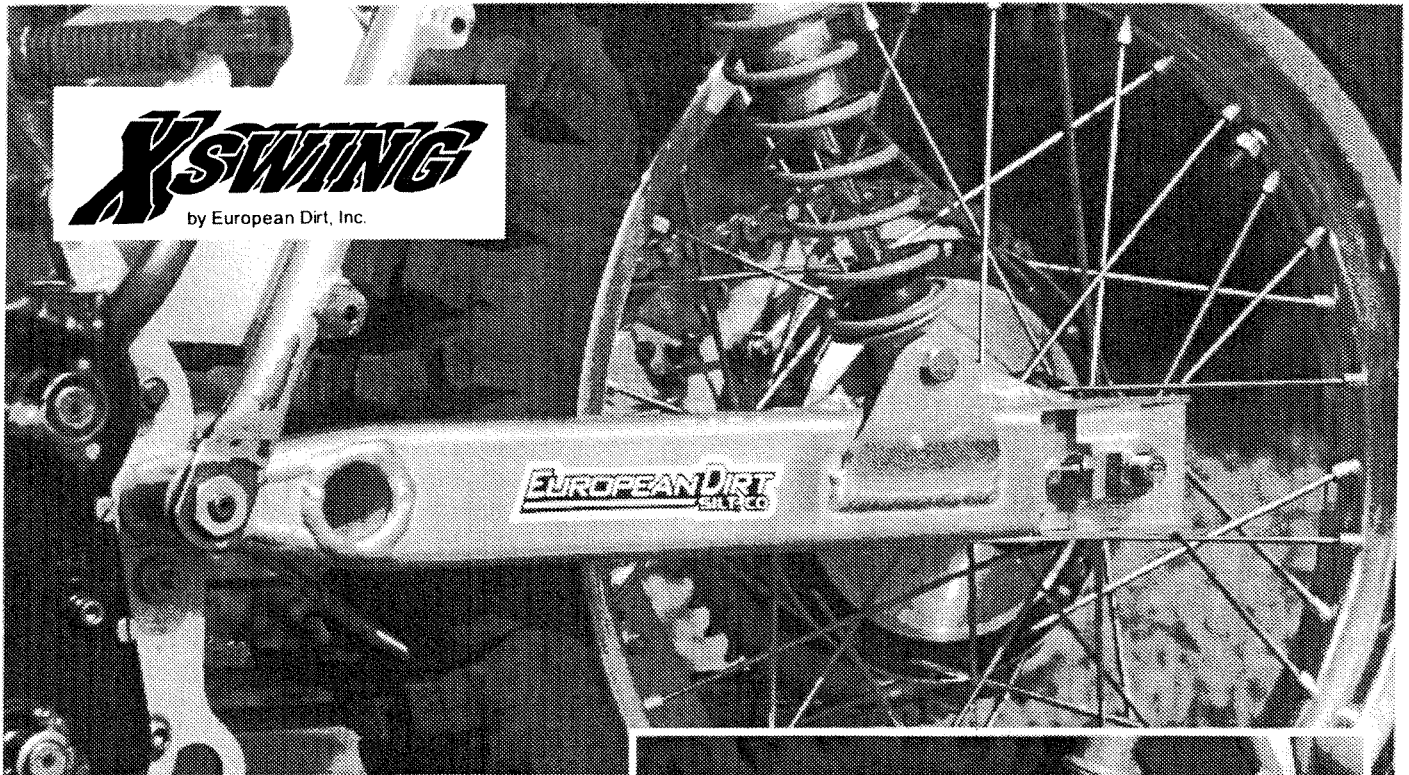

## Now Available

Aluminum Swing Arms for

- |                   |                       |
|-------------------|-----------------------|
| 72-84 Husky       | 73-81 Maico           |
| 74-77 OSSA        | 74 Honda CR 250       |
| 74 Suzuki TM      | 74-80 Montesa         |
| 74 CZ (long axle) | 71-78 Bultaco Pursang |

Custom arms also available - slightly more  
 Custom bends, shock mounts & lengths -  
 No problem! Any dual shock swingarm can  
 be reproduced.

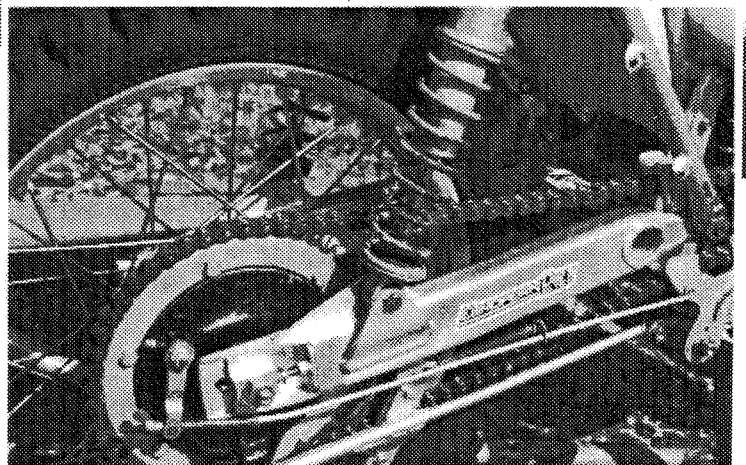

All normally \$349.....

**Special 2000 introductory offer \$295 plus S&H**

**Reproduction Decals & Badges  
 including water slides**

OSSA tank badges, Husky and more.

This vehicle does not conform to  
 the U.S. vehicle safety standards  
 and is used for racing only.

Made by HUSQVARNA AB  
 Huskvarna Sweden

**TANK RESTORATIONS**

Husqvarna '67 thru '83

Honda CR125

& 250 - '73 thru '78



See our website  
[www.rof.net/yp/eurodirt](http://www.rof.net/yp/eurodirt)

VISA and Mastercard welcomed  
 All prices shown in US\$

PO Box 111 521 Main Street Silt, CO 81652 U.S.A.

Tel & Fax + 1 970 876 5277

email [eurodirt@rof.net](mailto:eurodirt@rof.net)

# HUSKY REPRO PARTS

Husqvarna

Husqvarna

- \*Seat Foams
- \*Seat Covers
- \*Gasket Sets
- \*Seals / Bearings
- \*Filters
- \*Fenders, plastic & fiberglass
- \*Inner fenders; 66,67 & 68-74
- \*66-67 Rear Fenders (fiberglass)
- \*Air Cleaners (all)
- \*Cables

Parts new and used; Check us out first.



(480) 966-0101



Check our website at [www.amsracing.com](http://www.amsracing.com)

Coming soon, '67 250/360 handmade pipes, piston kits, 66-67 fiberglass seat bases.

**"WE RACE"**

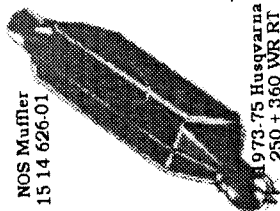

NOS Muffler  
15 14 626-01

1973-75 Husqvarna  
250 + 360 WR RT

NOS RT Mufflers -\$60  
+ship 304-267-6471

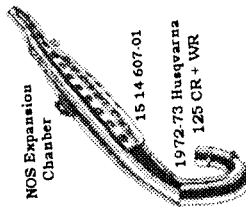

NOS Expansion Chamber

15 14 607-01

1972-73 Husqvarna  
125 CR + WR

NOS 72-73 Husky 125 expansion chambers \$120+\$20 ship call 304-267-6471 or e-mail - husky@intrepid.net

Specializing in Aftermarket Products for Vintage & Evolution Off-Road Motorcycle

**Online Catalog**

We UPS daily! M-F: 12-6 (EST)

[www.vintagemx.com](http://www.vintagemx.com)

**VMX**

(703) 707-8692

**WHEEL WORKS**

**SPECIALIZING IN**

- Lacing & Truing
- Chrome & Alloy Rims
- Stainless Spokes
- Powder Coating
- Polishing-Chroming
- Tires - All Brands
- Lowest Prices

**SALE!**

Excel Rims 18" and 21" **\$99.00**

**714 530-6681**

12787 Nutwood Garden Grove, CA 92640

**HUSQVARNA PARTS and SERVICE**

Machine Shop Full time specializing in Husqvarna Engine rebuilding, Case welding, frame repairs, N.O.S. and Used parts available..parts, parts, parts Wiseco piston specialist - custom applications - call

**We now have 390/430 pistons in stock**

**STAHL'S HUSQVARNA**

**Advance Tool and Die**

1700 S. Nebo Rd. 400W  
Yorktown, IN 47396  
Shop number- 765-284-7653

A Husky shop for past 30 years! Please call when I am in, as I will not be able to return parts search calls. Call Forest Stahl! Race and Restore Daily!

**Hall's Husqvarna**

Largest inventory of Husqvarna Parts for Vintage, Evo and Modern in Stock!

Also a Large Inventory of Cagiva Parts.

25 years experience in sales and service.

Parts Shipped Daily via UPS

**VISA-MASTERCARD-DISCOVER**

3801 N Dirksen Pkwy  
Springfield, IL 62707  
Phone 217-789-0107  
FAX 217-789-7408

Talk to Raymond!  
Talk to Jay Hall!

Hours:

Closed Sun/ Mon  
Tuesday 9-7  
Wednesday 9-6  
Thursday 9-6  
Friday 9-7  
Saturday 9-5